

ZB Refrigeration Scroll Compressor Catalogue



EMERSON
Climate Technologies

EMERSON. CONSIDER IT SOLVED.™

General Information	1-1
Features	2-2
Application guide	3-11
Installation and piping arrangement	12-14
Performance Data	15-29
R22 50Hz	15-16
R404A 50Hz	17-18
R134a 50Hz	19-20
R22 60Hz	21-23
R404A 60Hz	24-26
R134a 60Hz	27-29
Technical Data	30-31
Dimensions & Brazing Connection	32-39
ZB15-ZB26	32-32
ZB30-ZB45	33-33
ZB50-ZB58	34-35
ZB66-ZB88	36-37
ZB92	38-38
ZB11MC	39-39
Electrical Wiring Diagram	40-43
ZB15-ZB88	40-41
ZB92-ZB11M	42-43
Application Envelope	44-44
Model Nomenclature & BOM Summary	45-45

ZB Series

General Information

Copeland Corporation was established in 1921 in Detroit City, Michigan State, U.S.A. For more than 80 years, it has been our endeavour to bring cutting-edge products to create a healthy environment and safeguard food.

A Brief Timeline of Achievements:

- * first household refrigerator in the world, in 1921;
- * first semi-hermetic compressor in the world, in 1941;
- * first semi-hermetic compressor with butterfly valve in the world, in 1979;
- * first scroll compressor with dual compliance, in 1987;
- * first digital scroll compressor in the world, in 1996;
- * first commercial large horse power scroll compressor in the world, in 2001;
- * first electronic-display scroll compressor-condensing unit in the world, in 2002;
- * first digital scroll heating in the world, in 2004

Today, Emerson Climate Technologies continues to lead the global industry of refrigeration and air-conditioning compressors- with annual sales of over 2 billion dollars, technical service network spanning 120 countries and the largest compressor R&D centre in the world. Our global customers include highly reputed refrigeration and air-conditioning equipment manufacturers, supermarket chains, fast-food chains, hospitals, restaurants, laboratories, factories and schools. We constantly endeavour to provide you with high-quality compressors and after-sales service.

The introduction of scroll compressor in 1987 has revolutionized the refrigeration industry. The scroll compressor has several unique advantages: high energy-efficiency ratio, low noise level, high reliability and running cost. This revolutionary technology is being successfully used by manufacturers, dealers and end-users. To date, the number of scroll compressors manufactured by Emerson Climate Technologies has crossed the 40-million mark.

Scroll compressors have been successfully used in the air-conditioning industry, and the future of refrigeration belongs to the scroll compressor.

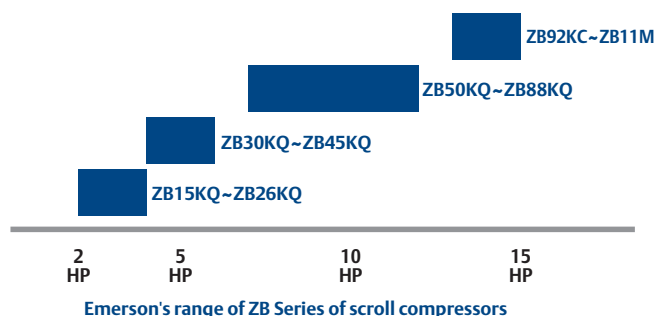

Features

Dual Compliance

This design ensures good sealing between the scroll spirals. It allows the scroll spirals to contact and separate along the radial and axial directions. Debris or liquid can go through the scroll disks without damaging the compressor. This results in:

- * longer lifetime and better reliability
- * better liquid handling capability
- * better handling of debris

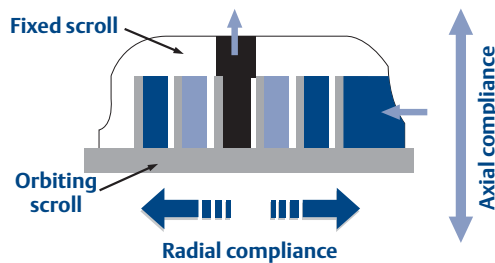

Designed for high energy-efficiency:

The scroll spirals in a scroll compressor wear in, rather than wear out. Over time, the wear-in improves performance. This ensures a very high volumetric efficiency.

Designed for lower noise and vibration:

The scroll design creates a smooth sound spectrum and better sound quality. The layout of the compression chambers is symmetric, making for very minimal imbalances. Manufacturing accuracy of scroll compressors is quite high. Scroll compressors do not normally require any vibration-absorbing device.

"Unloaded Start" technique

After shut down, the two scroll forms are separated from each other. This enables full internal pressure equalization at shut down. For this reason, additional start capacitors are not normally necessary at start-up of single phase models.

High-efficiency "Teflon" bearings:

High Efficiency "Teflon" is used for the upper main and drive bearing. "Space age" materials used in the compressor include:

- (1) Porous bronze
- (2) PTFE-lead overlay

There is exceptionally low friction. This also allows for extended operation without lubrication.

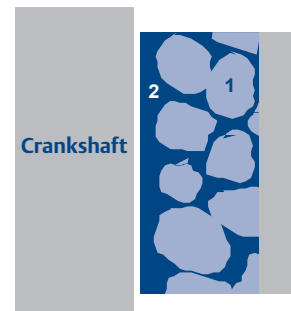

Copeland refrigeration scroll compressors offer outstanding solutions for medium and high temperature applications. ZB Series of refrigeration scroll compressors are ideal for compact system designs that require a high degree of reliability and energy-efficiency. Available ZB Series is in the range of 2-15HP. Applicable refrigerants include R22, R404A, R507 and R134a.

Refrigerating capacity data

Refrigerating capacity data listed in this manual are applicable for power frequencies of 50Hz (speed of motor equals 2900rpm) and 60Hz (speed of motor equals 3500rpm). The scope of compressor operation should not exceed listed conditions.

All specifications in this catalogue are subject to change without notice.

The scroll compression process :



Compression is accomplished by reducing the size of the outside pockets as the scroll relative motion moves them inwards towards the discharge port



Suction is sealed off as gas is drawn into the spiral.



Orbiting motion moves the gas toward the center of the scroll pair and pressure rises as pocket volumes are reduced



The gas reaches the central discharge port at discharge pressure

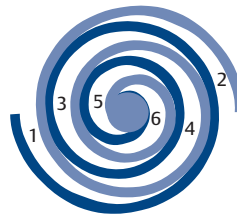

Six distinct compression paths operate simultaneously in a scroll set. The discharge and suction processes are nearly continuous

A simple scroll concept was first invented in 1905. As shown in the above drawing, a Copeland Scroll® has two concentric scrolls, one inserted within the other. One scroll remains stationary as the other orbits around it. This movement draws gas into the compression chamber and moves it through successively smaller "pockets" formed by the scroll's rotation, until it reaches maximum pressure at the center of the chamber from where it is released through a discharge port in the fixed scroll.

During each orbit, several pockets are compressed simultaneously- so the operation is virtually continuous.

Configuration of the scroll compressor

Type of compressor	Built-in pressure relief valve	Discharge temperature protection	Unidirectional discharge valve	Motor protection
ZB15-ZB45	IPR	TOD	Yes	Neutral protection
ZB50-ZB88	IPR	ASTP	Yes	Neutral protection
ZB92-ZB11M	NA	Built-in sensor for discharge temperature	NA	External protection module of motor + Built-in sensor

Internal Pressure Release valve (IPR)

A built-in relief pressure valve is mounted between the high-pressure and low-pressure side of the compressor. If the pressure difference between the high- and low-pressure exceeds 26-32bar, the internal pressure release valve opens. At the same time, the hot discharge gas comes in contact with the temperature sensor of the motor protector. As a result, the internal motor protector trips. Once the compressor has cooled, the motor protector can be reset.

Models ZB92 and ZB11M do not have the in-built pressure relief valve. In order to ensure safe operation, the system configuration should include a high-pressure switch whose setting pressure does not exceed 30bar (gauge pressure).

Internal temperature protection

Therm-O-Disc (TOD) or ASTP is a temperature-sensitive snap disc device installed at the scroll outlet. If the discharge temperature is excessively high, the valve will open to allow the high-temperature suction gas to return and contact with the motor protection, so as to protect the compressor.

Motor protection module

Both ZB92 and ZB11M motor protection systems include an external protection module for the motor. The module is connected with four thermistors in series built into the motor windings and a fifth thermistor mounted at the internal discharge port of the scroll disks. If either motor or discharge temperature exceeds the limit value, the module will trip and can only be reset after 30 minutes. (Note: if the power supply of the module is cut off, the module will reset at once.) The time-delay is set at 30 minutes in order for the scroll compressor to cool down fully. If the compressor is restarted without a time-delay, a destructive temperature-surge will be caused in the compressor. For this reason, the power supply of the module must not be clubbed together with the control circuit (see also the schematic wiring diagram).

Field troubleshooting of the motor protection module

Cut-off the power supply of the control circuit, and bypass the motor protection module. Remove the conductor of the control circuit from M1 and M2 terminals of the module, and connect a jumper wire to bypass the control circuit of the module. (Note: thus far the motor protection module inside the compressor has been bypassed, but this method can only be used to test the module.)

Switch on the control circuit and the power supply of the module again, and commission the compressor: if the compressor does not operate when the module is by-passed, the fault is not in the control system and the module. If the compressor operates when by-passing the module, but fails to operate by connecting the module again, the relay in the control circuit of the module is undoubtedly cut-off. Now, the thermistors' series must be tested in order to determine the reason why the relay in the control circuit of the module is cut-off: either the internal temperature is too high or elements in the control circuit are faulty.

Check the thermistors' series:

Cut-off the control circuit and the power supply of the module, and remove the lead wire of the sensor from S1 and S2 terminals of the module, and measure the resistance of the thermistor series via the sensor by means of an ohmmeter. (**Caution:** use an ohmmeter of 9V maximum resistance to check the series; the sensor is sensitive and vulnerable; do not try to check the electrical conductivity of the sensor by means of any non-resistance tools; do not apply any external voltage to the sensor - the compressor could be damaged and may even have to be replaced.)

Diagnose resistance readings according to the following data:

- 150-2250 Ω : normal running range;
- $\geq 2750\Omega$: the compressor superheats: rest the compressor for a sufficiently long period to allow it to completely cool down;
- 0 Ω : the sensor has been short-circuited, change the compressor;
- $\infty\Omega$: the sensor circuit is cut-off, change the compressor.

If the resistance readings are outside the range of normal values, pull out the connector plug on the sensor and measure the resistance at the sensor terminals. One can determine the reason why the readings are not normal and establish whether the fault lies with the connector or thermistor.

After compressor start or any module trip, the resistance of the sensor series must be below the resetting point of the module before it closes again. Its resetting value equals 2250-3000 Ω . If the resistance of the sensor series is below 2250 Ω and the compressor cannot be put into operation through by-passing the control circuit, it indicates solid-state module damage and should be exchanged.

During the test period, the voltage should be cut-off to prevent short-circuit and accidents at the contacts. Whenever the circuit breaker disconnects or trips, the module function should be checked, to ensure that the module contacts haven't been bound.

Minimum operating time

The number of times a compressor can start and stop within a period of one hour depends on the system configuration to a great extent. By nature, the scroll compressor starts unloaded; therefore the minimum operation time is not specified. The quantity of lubricating oil that returns to the compressor at start is, however, a critical measurement. The simplest is by means of the sight glass (optional item), but the longest piping permitted for the system should be connected at the time of this measurement.

The minimum operation time means the time necessary for the normal oil level in the sight glass to be restored from compressor start-up to shut-down. If the compressor start-stop cycles are shorter than the minimum operation time, for example, to maintain exact temperature control, the compressor will gradually lose the lubricating oil and may even be damaged. For more information on compressor start-stop cycle and frequency, see the engineering application manual numbered 17-1262.

Accessories

Discharge temperature protection

If the system design does not ensure compressor operation within the range specified or if the system layout is not reasonable, very high discharge temperature could be caused, thereby leading to carburization of the lubricating oil, irregular compressor operation or even compressor failure. A Discharge Temperature Controll (DTC) valve should be installed in the system.

The DTC valves supplied by Emerson are as below. The control circuit will be cut off when the discharge temperature exceeds 126°C.

Compressor Models	DTC type	Lead wire terminals	Alarm interface	Suitable pipe size
ZB15-ZB45	998-0540-00	NA	NA	1/2"
	998-0548-00	NA	Yes	
	998-7022-02	Yes	Yes	
ZB50-ZB88	998-0540-03	Without lead wire	NA	7/8"
	998-7022-05	With lead wire	NA	

When the compressor is not equipped with a block valve, the DTC is installed at a distance of 178mm from the outlet. When the compressor is equipped with a block valve, the DTC is installed at a distance of 127mm from the outlet. When installing the block valve, the DTC should adhere to the surface of the discharge pipe, and should be fixed by means of the clamp supplied with the assembly. Copeland DTC can be connected with 120V or 240V control circuit.

ZB Series

Application guide

Crankcase heater

Single-phase scroll compressor does not require installation of a crankcase heater.

When the refrigerant charge exceeds the values listed in the following table, or, when the refrigerant is charged at-site, a crankcase heater is necessary for the three-phase compressor.

Compressor Models	Refrigerant Charge(kg)
ZB15-ZB45	4.5
ZB50-ZB88	7.2
ZB92-ZB11M	7.7

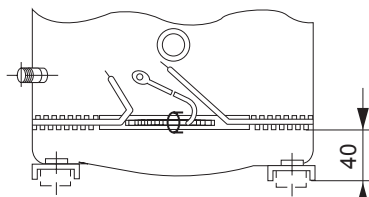

Installation of the crankcase heater

Pressure controller

To ensure the safe operation of the refrigeration system, Emerson suggests that all systems be equipped with high- and low-pressure switches.

See the following table for the recommended setting values (unit: bar, gauge pressure).

Control type	R22	R404A/507	R134a
High pressure (maximum)	26	30	18
Low pressure (minimum)	1.7	1.15	0.3

Gas-liquid separator

Copeland scroll compressor has a greater capacity to resist liquid because of some inherent characteristics. It is possible that the gas-liquid separator does not need to be used in most of the systems. However, it is suggested that the gas-liquid separator be used when:

- * a large quantity of the liquid refrigerant in the system returns continuously into the compressor within a period of regular stop
- * there is defrosting
- * there is a variable load regardless of the charged quantity of refrigerant in the system
- * it is impossible to control the liquid-return phenomenon or wet start because of the dilution of lubricating oil

If the gas-liquid separator is used in the system, it is suggested that the dimension of the return oil orifice should be within 1-1.9mm. Also, the filtering area of the protecting screen should be large enough, and its mesh size not below 30x30 (diameter of 0.6mm). It is not advisable to use screen finer than 30x30 mesh in the system anywhere in order to protect the orifice from being blocked by debris.

Drying filter and humidity indicator

The filter drier installed in the liquid piping should be large enough and adequate for uninterrupted operation. The dehumidifier should be selected according to the flow rate of the refrigerant. Do not use dehumidifiers that can turn into liquid state after absorbing a large quantity of wet steam, such as potassium chloride. It is suggested that porous block dehumidifiers are used to absorb the wet steam or acid and prevent metal fragments from invading. The filter drier should be installed after a second vacuum operation has been carried out. The sight glass for the humidity indicator should be installed in a clearly visible position on the liquid piping, in order to facilitate the checking of refrigerant flow rate.

Filter for the suction piping

To avoid compressor faults, all impurities (fouling products, welding scale, borax and metal fragments etc.) must be removed from the system before start of operation. The impurities can go into the compressor suction area even through the micro filter because of the extremely fine size of impurities. When the assembly is carried out at-site and the necessary cleanliness cannot be ensured, it is suggested that a high-capacity filter is used for the suction (there is only a very small pressure drop). A pressure gauge should be placed before the filter to detect the pressure drop arising from the filter.

Oil separator

When installing the oil separator, it must be charged with the lubricating oil until the valve begins to open. The oil quantity in the oil separator should be maintained at all times. If not, the oil in the compressor will be drawn off by the oil separator; consequently the oil quantity will decrease gradually.

Refrigerant and oil

The refrigerants R22, R404A, R507 and R134a etc. can be used in ZB Series scroll compressors. If any of the environmentally-friendly refrigerants, namely, R134a, R404A, R507 etc. are used, an ester lubricating oil must be used (POE oil). The residual water content in a system charged with POE oil must be below 50ppm. This is because of the highly hygroscopic nature of ester oil. Such a measurement can be carried out only after the system has run for 48 hours. A good filter-drier of large capacity may be installed according to the system and refrigerants.

At the time of commissioning, an appropriate capacity of vacuum-pump must be selected. Parts used with the system must be selected keeping in mind the characteristics of the refrigerant (consult with the part manufacturer about details). These include:

Expansion valves

Filter-Dryer

Valves, fittings and control devices.

These would change depending upon the change of the mass flow rates of refrigerants.

Oils

Mineral oil is not adaptable for systems working with the new refrigerants, because it is not compatible with this kind of refrigerant. It has already been verified that POE lubricating oil can replace mineral oil. To ensure a long working life, the performance characteristics of polyester oil must be specifically noted. Only certified ester oils may be used with the new refrigerants R404A, R134a, R407C and R507. They should be mixed according to specified guidelines. To prevent the mineral oil and the polyester oil from polluting each other, the devices for traditional refrigerants and new refrigerants, such as vacuum-pump, pipe fittings, charge and reclamation equipment and other parts should be clearly distinguished and serviced.

Poly Ester Oil has a very strong hygroscopic property. The chemical stability of the lubricating oil will be affected if it draws in moisture. During storage and transportation, the compressor is charged with dry nitrogen to prevent the penetration of moisture. During installation, the exposure of the compressor outlet should be minimized in every possible way.

Ester oils certified by Copeland: EAL Arctic 22CC, Mobil Co.;
Emkarate RL 32CF, ICI Co.

Mineral oils certified by Copeland: Suniso 3GS, Sun Oil Co.;
Capella WF32, Chevron/Texaco Co.

Please see also Copeland operating instruction manual AE17-1248 for details of Copeland-approved lubricating oils. System manufacturers should provide data for refrigerants on the nameplate.

Typical layout of suction piping

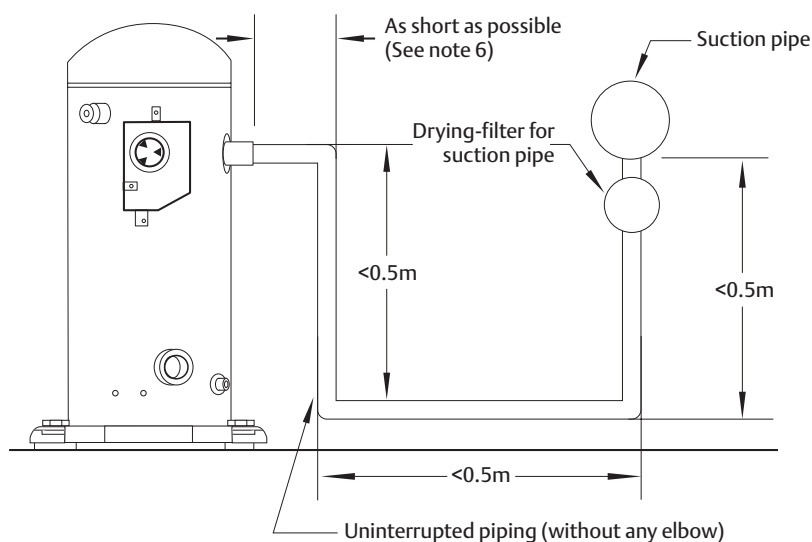

Notes:

1. The purpose of the above-mentioned piping layout is to decrease the stress in the piping.
2. Design of discharge and return oil piping should also comply with this principle.
3. If the length of pipe exceeds 0.5m, measures should be taken to fix it.
4. If there is a heavier load on the piping (such as a filter-drier), due care should be given to fixing.
5. It is advised that the length of the pipe not drop below 0.2m.
6. Piping sections should be small as far as possible (50mm or shorter). At the same time, adequate welding length should be ensured.
7. Copeland does not recommend using an elbow to connect piping sections, and recommends using copper tubes without joints or turns.

Installation and piping arrangement

Installation of the compressor should be done according to the service conditions. The selected installation and piping design should dampen the transmission of noise and vibration as far as possible. Please see also the following table for tightening torques:

Reference table for tightening torque

	Torque (N.m)
Rotalock screw valve 3/4"-16UN	40-50
Rotalock screw valve 1 1/4"-12UN	100-110
Rotalock screw valve 1 3/4"-12UN	170-180
Rotalock screw valve 2 1/4"-12UN	190-200
Flange with M16 stud	102-113
Oil level sight glass	25-25.5
5/16", M9 installation stud	Maximum 27
Soft foot	12-14
Connecting screw in terminal box	2.5-2.6

Mounting

The single-compressor-condenser unit makes use of soft rubber grommets for mounting. When the compressors are used for tandem operation, they are mounted by means of steel spacers or two steel rails. This rigid mounting keeps the interconnecting tubing stresses to a minimum. The tandem assembly should be mounted on rubber isolating grommets to the unit base pan. Both compressors must be at the same level to prevent oil from migrating to the lowest compressor through the oil equalization line.

Pipeline

During installation, great care should be taken to keep the piping lines of the refrigerating equipment extremely clean. In principle, the refrigerating equipment should always have clean and dry pipelines, and there should not be any scale, rust and phosphate layer on it. Dry nitrogen must be charged in the pipeline during welding. To prevent the welding joints in the pipeline from producing fowl, the welding temperature must be carefully controlled. The welding operation should not be carried out on pipeline that contains refrigerant (even if the refrigerant is not under pressure), because the heating of refrigerant, oil and air will form a toxic gas. The pipeline design must ensure that, even at part load, the lubricating oil returns to the compressor despite low gas flow velocity in the suction and discharge pipes.

Welding of the pipeline for the scroll compressor

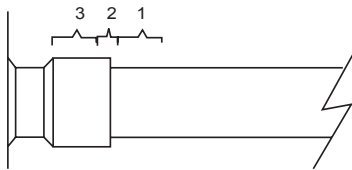

First-Time installation:

- * The suction pipe for scroll compressor is a copper-plated steel pipe and its welding technology is similar to that for other copper pipes.
- * Recommended solder: Any copper-silver alloy material is suitable, but the alloy should preferably contain at least 5% silver.
- * Before installation, make sure that both the internal surface of the suction pipe nozzle and the external surface of the suction pipe are clean.
- * Heat up the area 1 by means of a two-tip welding gun. After the pipe temperature approaches welding temperature, the flame of the welding gun is moved over to the area 2.
- * Heat up area 2 to welding temperature. To make the pipe temperature uniform, the welding gun should be moved up and down, and if necessary, the welding gun can be rotated around the pipe. The solder is added to the connector and at the same time the welding gun is rotated around the connector to make the solder flow along its periphery.
- * After the solder flows around the connector, the welding gun should be moved to area 3 in order to heat up, so that the solder can be drawn in the connector.
- * Excessive heat will create poor welding connections.

Field service

- * Disconnect: Reclaim the refrigerant from the high-pressure and low-pressure side of the system simultaneously.
- * Connect again
- * Recommended welding material: A solder that contains 5% silver at least, or a copper-silver alloy with a soldering flux.
- * Insert a pipe in the connector and connect with the system.
- * Operate according to the First-Time installation guide.

Control of oil level when running parallel

The Copeland refrigeration scroll compressor is suitable for running in parallel. An adequate oil level in the compressor must be ensured in the process. When the oil level is below the setting one, the oil level controller allows the compressor to continue running for a period of time. Thereafter, if the oil level is still not adequate, the compressor stops running.

Caution: The following models are not certified by Copeland for parallel connection: ZB50, ZB58, ZB66, ZB76 and ZB88.

Installation and piping arrangement

Electrical connection

Power supply voltage and connecting terminals

Please note the direction of the connecting terminals in the connecting box (single-phase power: R, S, C; three-phase power: T1; T2; T3). To ensure normal start and operation of the compressor, the power supply voltage should not drop more than 10% below the rated voltage for the compressor.

Starting characteristics of the single-phase compressor

The single-phase scroll compressor is equipped with a permanent fractional capacitor motor (PSC). Auxiliary starting equipment is unnecessary for most applications. But auxiliary starting equipment is necessary for some applications (for example, if the starting voltage is lower). In the latter case, a starting capacitor and a secondary relay may be used at start-up.

Rotation direction of three-phase compressor

The compression process of the scroll compressor occurs only in one direction. The single-phase compressor starts and operates based on a correct direction of rotation (except under such conditions where the power supply is abruptly cut off). The direction of the rotation for the three-phase compressor depends on the phase sequence of the power supply. Hence, the compressor has a 50% chance of "reverse-rotation".

When the installation operation is carried out at-site, the correct direction of the rotation can be judged by discharge pressure increase and suction pressure decrease. However, if the compressor is running in reverse direction, the compressor will give out an abnormal noise and the current draw will clearly be lower than the rated value as well.

A brief reverse-rotation is harmless to the compressor. But a reverse-rotation for long periods can damage the compressor. Equipment manufacturers can place a phase sequence protection module in the control circuit to ensure that the machine will not operate in case of incorrect phase sequence. Since there is a 50-50 chance of connecting power in such a way as to cause rotation in the reverse direction, it is important to include notices and instructions in appropriate locations on the equipment to ensure proper rotation direction is achieved when the system is installed and operated.

Instantaneous Power Shut-Off

Instantaneous shut-off (power-off time is below 0.5 sec.) can lead to change in the direction of rotation of the single-phase compressor. After shut-off, the compressor operation will last several minutes in the reverse direction until the internal motor protector of the compressor is triggered. The compressor will not be affected in this process. After the motor protector resets, the compressor will re-start and operate in the correct direction of rotation.

Copeland recommends using a relay that can respond to this instantaneous shut-off. The relay helps to re-start the compressor automatically after a time-delay of two minutes. Three-phase compressors do not need a relay.

High-voltage test

The motor of the refrigerating scroll compressor is in a casing. After charging refrigerant into the system, the motor could be immersed into the liquid refrigerant. When the liquid level in the casing is higher, the result of the high-voltage test could indicate a higher current value, because the conductivity of the liquid refrigerant is higher than that of the gas or the lubricating oil. This phenomenon will only happen when the compressor motor is entirely immersed in the liquid refrigerant, but there is no safety issue.

Evacuation (drying)

The system must be evacuated after current leakage test. A vacuum pump must be used to evacuate. **The compressor should never be used for self-evacuation.** To evacuate, it is suggested that the vacuum pump be connected to the high and low-side evacuation valves with copper tube or high-vacuum hoses (with internal diameter of at least 8mm). The sum of the sectional areas of all connecting pipes should not be below the sectional area of the inlet pipe for the vacuum pump.

Installation and piping arrangement

The connecting pipe (high-pressure rubber pipe or copper tube **ø10x1 mm**) for the vacuum pump should be as short as possible with no bends or kinks. The evacuating capacity will evidently reduce owing to the kinks and joints. Also, it should be noted that the indicated value of the vacuum gauge is unlikely to comply with the vacuity at the end of the system, because the vacuum gauge is usually placed on the vacuum pump. Hence, the evacuating time should be extended to ensure uniform vacuity throughout the system. A vacuum pump whose evacuating rate is 40-50 l/min is enough to meet the demands of medium/small-sized equipment. Larger equipment should be connected with a tube whose inner diameter is above 10mm or with a copper-tube (**ø12x1 mm**, **ø15x1 mm**) equipped with a correspondingly large-sized evacuating valve. Evacuation should be carried out with a two-stage vacuum pump. The vacuity must be measured by a vacuum gauge instead of a conventional gauge. The system should be evacuated at least twice until the vacuity is 2mbar (1.5torr). Then, the vacuum should be broken with dry nitrogen, followed by evacuation of the whole system including the compressor. The vacuity reaches 0.7mbar (about 0.5torr) by means of the third evacuation. The refrigerant may finally be charged in the system to bring gauge pressure to 0.15bar.

Caution: In order to prevent motor damage, do not start the compressor or conduct any electric test under vacuum. Do not allow the compressor to run under vacuum condition.

It is important to be careful and exact when evacuating and drying. Air remaining in the system in the process of installation will lead to rise in discharge temperature and the lubricating oil carburizes, thereby affecting the quality of lubricating oil and causing compressor failure. The moisture and air will generate acids and corrode the metal resulting in deterioration of lubricating oil quality. These phenomena will be quick to form under high-pressure and high-temperature conditions.

Charging of refrigerant

The refrigerating equipment can only be charged with a designated and selected refrigerant. The running effectiveness depends on the correct charge quantity of refrigerant. If the charged quantity of refrigerant is insufficient, refrigerant in the evaporator will be insufficient as well, resulting in a drop of suction pressure and discharge efficiency, thereby causing the motor to overheat. If the quantity of refrigerant charge is in excess, there is excess liquid refrigerant in the condenser as well, causing a rise in condensing pressure and compressor failure arising from liquid return.

The liquid refrigerant should be charged from the high-pressure and low-pressure side simultaneously. Most of the charging quantity should be from the high-pressure side. The refrigerant cylinder should be weighed before and after charging to determine the physical charged quantity.

A basic method used to charge liquid refrigerant is to make the refrigerant pass through a filter-drier placed in the charging pipe. The refrigerant is charged via a cut-off valve or a charge valve with a joint to the liquid reservoir.

A more common way to determine the charge quantity is observe the liquid refrigerant flow in the sight glass of the liquid piping. When the refrigerant flow is visible, it can be assumed that the refrigerant is charged properly, because the normal operation of the expansion valve depends on the uninterrupted flow of liquid refrigerant. The emergence of foam indicates insufficient refrigerant.

However, the use of sight glass as an effective tool to determine the charged quantity of refrigerant is not entirely advisable. It may be noted that, at times, foaming may still be observed from the sight glass, in spite of sufficient refrigerant charge. One of the reasons is that there is a vent above the sight glass in the liquid piping which results in foam when the liquid pressure decreases. Also, any quick change in condensing temperature, such as from the condenser fan not starting, can cause this sudden evaporation. The criteria to judge whether or not the charged quantity of the refrigerant is adequate are the super heat temperature of the return gas and the sub cooling temperature of liquid refrigerant.

Installation and piping arrangement

Casing temperature

When the compressor is running, the discharge chamber including the discharge piping is under extremely high temperature. It is to be noted that wires and other materials that are susceptible to such high temperature should not come in contact with these parts. Make sure to avoid physical contact with the discharge piping and chamber to ensure personal safety.

De-assembly of system

Caution: Before opening the system, the refrigerant has to be released from the high-pressure side and the low-pressure side simultaneously. Make sure that the gauge registers pressures at the high- side and low-side as being equal to 0 (gauge pressure). Then, the de-assembly operation may be carried out, or the compressor can be removed by disconnecting the piping of the system.

Replacing compressor

In the case of a motor burn, the majority of contaminated oil will be removed with the compressor. The rest of the oil is cleaned through use of suction and liquid line filter dryers. A 100% activated alumina suction filter drier is recommended but must be removed after 72 hours. See Application Engineering Bulletin 24-1105 for clean up procedures and AE Bulletin 11-1297 for liquid line filter-drier recommendations. **It is highly recommended that the suction accumulator be replaced if the system contains one.** This is because the accumulator oil return orifice or screen may be plugged with debris or may become plugged shortly after a compressor failure. This will result in starvation of oil to the replacement compressor and a second failure.

Function detection of Copeland scroll compressor

The way the suction valve is closed can't be used to check the attainable minimum suction pressure and to test the compressor performance. This test will damage the scroll compressor. The following diagnosis methods can be used to judge whether or not the function of a scroll compressor is normal.

Check for supply voltage

A routine inspection of the motor winding conductivity and ground leakage is carried out so as to determine whether or not the motor winding itself short-circuits and the insulation-to-earth short-circuits. **If the neutral protector trips, the compressor must be allowed to cool down completely in order to close the motor protector.**

Check evaporator fan and condenser fan operation. Connect the gauge with the suction side and the discharge side, and switch on the power supply. If the suction pressure is below the normal value, it is possible that the refrigerant charge quantity is insufficient or there is blockage in the system interior.

As far as the three-phase compressor is concerned, if the suction pressure does not drop and the discharge pressure does not increase to the normal value, two of the power line terminals are exchanged to ensure that the rotation direction of the compressor is correct. If the pressure in the compressor still fails to reach the normal value, it is possible that the compressor has been damaged.

To test compressor discharge, the current consumption of the compressor must be compared with the published specifications under same operating pressure and system voltage. If the deviation between the measured average current and the published value exceeds $\pm 15\%$, it indicates compressor damage. If the balance of the three-phase currents exceeds 15% of the average current, it could indicate voltage imbalance. A further inspection should be carried out. More detailed troubleshooting procedures for compressor and system problems can be found in chapter H of the Copeland Electrical Handbook.

Before returning the compressor, it must be clearly established that the compressor has been damaged. Before returning the compressor, high-voltage tests should be carried out on motor winding resistance and motor starting capacitor.

Performance Data

Q=Capacity (Watts) P=Power input (Watts)

50 Hz

Model	Con. Temp. °C	Evaporating Temperature °C						
		-12	-10	-5	0	5	10	
ZB15KQ	Q	30	3700	4000	4800	5800	6900	8200
		40	3300	3550	4350	5200	6250	7400
		50	2790	3050	3750	4550	5500	6550
	P	30	1080	1080	1090	1140	1220	1380
		40	1450	1440	1420	1420	1450	1510
		50	1870	1870	1840	1810	1800	1800
ZB19KQ	Q	30	4000	4350	5300	6400	7700	9100
		40	3650	3950	4850	5850	7000	8300
		50	3200	3500	4350	5250	6300	7500
	P	30	1270	1260	1250	1230	1210	1190
		40	1610	1600	1590	1570	1550	1530
		50	2020	2020	2000	1980	1960	1940
ZB21KQ	Q	30	5150	5600	6800	8150	9650	11400
		40	4650	5050	6200	7450	8850	10500
		50	4050	4400	5500	6600	7900	9450
	P	30	1610	1600	1620	1660	1700	1730
		40	1990	1990	2010	2040	2080	2100
		50	2480	2480	2500	2530	2560	2570
ZB26KQ	Q	30	5650	6100	7450	9000	10750	12750
		40	5100	5550	6800	8200	9850	11700
		50	4500	4900	6050	7350	8850	10550
	P	30	1770	1770	1750	1720	1700	1670
		40	2240	2230	2210	2190	2160	2130
		50	2810	2800	2780	2760	2730	2690
ZB30KQ	Q	30	6150	6800	8600	10700	13050	15700
		40	5400	6050	7700	9650	11900	14400
		50	4600	5150	6800	8550	10600	12900
	P	30	2230	2230	2250	2270	2310	2370
		40	2690	2700	2710	2720	2740	2770
		50	3280	3280	3290	3290	3300	3310
ZB38KQ	Q	30	8150	8900	11000	13400	16000	18800
		40	7300	8000	9950	12200	14650	17300
		50	6250	6900	8800	10800	13100	15600
	P	30	2490	2510	2540	2590	2680	2820
		40	3100	3120	3150	3200	3290	3430
		50	3880	3890	3900	3940	4010	4130
ZB45KQ	Q	30	10350	11200	13550	16300	19300	22800
		40	9400	10200	12400	14900	17800	21000
		50	8200	8950	11100	13350	16000	18900
	P	30	3160	3160	3170	3190	3220	3270
		40	3880	3870	3870	3880	3890	3920
		50	4810	4800	4780	4780	4780	4790

* Capacity based on 20°C suction temp, no sub-cooling.

* The highest suction temp is 0°C

Performance Data

Q=Capacity (Watts) P=Power input (Watts)

50 Hz

Model	Con. Temp. °C	Evaporating Temperature °C						
		-12	-10	-5	0	5	10	
ZB50KQ	Q	30	11990	12910	15700	18900	22600	26900
		40	10600	11660	14350	17400	20800	24700
		50	8900	9750	12550	15500	18800	22400
	P	30	3430	3440	3470	3500	3540	3600
		40	4350	4350	4340	4360	4390	4430
		50	5400	5550	5500	5450	5450	5450
ZB58KQ	Q	30	13350	14500	17700	21400	25700	30500
		40	11800	12950	16100	19600	23500	28000
		50	10150	11050	14150	17400	21100	25300
	P	30	3890	3900	3920	3970	4050	4190
		40	4880	4880	4880	4910	4960	5050
		50	6000	6150	6100	6100	6100	6200
ZB66KQ	Q	30	15300	16600	20100	24200	28800	34000
		40	13950	15100	18400	22200	26500	31500
		50	12450	13400	16500	20000	23900	28400
	P	30	4270	4300	4360	4430	4540	4690
		40	5350	5350	5400	5450	5550	5700
		50	6550	6700	6750	6750	6800	6900
ZB76KQ	Q	30	18000	19600	23800	28100	33000	38500
		40	16400	17800	21700	25800	30500	35500
		50	14700	15800	19500	23400	27700	32500
	P	30	4980	5000	5100	5600	5700	5850
		40	6300	6300	6350	6800	6850	6950
		50	7750	7950	8000	8250	8300	8400
ZB88KQ	Q	30	21000	22600	27400	33000	39000	45500
		40	18800	20400	24900	30000	36000	42000
		50	16600	17800	22000	26800	32000	38000
	P	30	5650	5700	5750	5900	6100	6400
		40	7100	7150	7200	7300	7400	7600
		50	8700	8950	9050	9100	9150	9250
ZB92KC	Q	30	21400	23100	27700	33000	39500	46500
		40	19500	21000	25300	30000	36000	42500
		50	17300	18700	22800	27200	32500	38000
	P	30	4450	6550	6800	7150	7600	8250
		40	7850	7950	8150	8450	8750	9200
		50	9450	9550	9800	10000	10300	10600
ZB11MC	Q	30	26100	28100	34000	40500	48000	56500
		40	23700	25600	31000	37000	44000	52000
		50	21000	22800	27800	33500	39500	47000
	P	30	7750	7850	8100	8450	8950	9650
		40	9450	9550	9800	10000	10400	10800
		50	11400	11500	11800	12000	12300	12600

* Capacity based on 20°C suction temp, no sub-cooling.

* The highest suction temp is 0°C

Performance Data

Q=Capacity (Watts) P=Power input (Watts)

50 Hz

Model	Con. Temp. °C	Evaporating Temperature °C							
		-25	-20	-15	-10	-5	0	5	
ZB15KQE	Q	30	2300	2880	3550	4350	5250	6250	7450
		40	1870	2400	3000	3700	4450	5350	6350
		50		1840	2370	2950	3600	4350	5150
	P	30	1270	1270	1250	1220	1200	1170	1160
		40	1690	1670	1630	1590	1550	1510	1490
		50		2260	2180	2100	2030	1970	1920
ZB19KQE	Q	30	2890	3550	4350	5250	6300	7500	8900
		40	2490	3050	3750	4550	5450	6500	7700
		50		2540	3100	3750	4550	5450	6450
	P	30	1490	1490	1480	1480	1470	1470	1470
		40	1880	1880	1880	1870	1860	1850	1840
		50		2380	2370	2360	2340	2320	2300
ZB21KQE	Q	30	3450	4300	5250	6350	7650	9100	10750
		40	3000	3700	4550	5500	6600	7900	9350
		50		3100	3750	4550	5500	6550	7800
	P	30	1770	1770	1770	1760	1760	1750	1750
		40	2240	2240	2240	2230	2220	2210	2190
		50		2830	2830	2820	2810	2790	2770
ZB26KQE	Q	30	4050	5000	6100	7350	8850	10550	12500
		40	3500	4300	5250	6350	7650	9100	10800
		50		3550	4350	5300	6400	7650	9100
	P	30	2080	2080	2080	2070	2060	2050	2050
		40	2640	2630	2630	2620	2610	2590	2580
		50		3320	3310	3300	3280	3260	3240
ZB30KQE	Q	30	4750	5900	7200	8700	10450	12450	14650
		40	4050	5050	6200	7500	9050	10750	12750
		50		4150	5100	6200	7500	9000	10750
	P	30	2390	2380	2370	2360	2340	2330	2320
		40	3020	3010	3000	2980	2950	2930	2910
		50		3810	3790	3770	3740	3710	3680
ZB38KQE	Q	30	5900	7300	8900	10800	12950	15400	18200
		40	5100	6250	7700	9300	11200	13350	15800
		50		5200	6350	7750	9350	11200	13300
	P	30	2990	3000	3000	2990	2970	2950	2920
		40	3750	3760	3760	3760	3760	3740	3710
		50		4670	4680	4680	4680	4670	4650
ZB45KQE	Q	30	6950	8600	10550	12750	15300	18200	21500
		40	6000	7400	9050	10950	13150	15700	18600
		50		6150	7500	9100	10950	13100	15600
	P	30	3440	3430	3420	3400	3380	3340	3310
		40	4300	4310	4310	4300	4280	4240	4210
		50		5350	5350	5350	5350	5300	5300

* Capacity based on 20°C suction temp, no sub-cooling.

Performance Data

Q=Capacity (Watts) P=Power input (Watts)

50 Hz

Model	Con. Temp. °C	Evaporating Temperature °C							
		-25	-20	-15	-10	-5	0	5	
ZB50KQE	Q	30	7850	10000	12400	15000	18000	21500	25400
		40	6100	8250	10500	12900	15600	18600	22000
		50		5900	8100	10350	12750	15400	18300
	P	30	4070	4080	4090	4110	4140	4170	4210
		40	5118	5130	5135	5150	5145	5140	5135
		50		6550	6500	6450	6400	6400	6350
ZB58KQE	Q	30	8900	11250	13950	17000	20600	24600	29200
		40	7050	9250	11700	14400	17500	21000	24900
		50		6900	9100	11500	14150	17100	20400
	P	30	4560	4570	4590	4610	4640	4670	4690
		40	5850	5800	5750	5750	5750	5750	5750
		50		7450	7350	7250	7200	7150	7150
ZB66KQE	Q	30	10350	12800	15600	18900	22600	27000	32000
		40	8900	11100	13550	16400	19600	23400	27600
		50		9150	11300	13700	16400	19600	23100
	P	30	4970	5000	5100	5150	5250	5350	5500
		40	6200	6250	6300	6350	6400	6450	6550
		50		7850	7870	7900	7900	7900	7950
ZB76KQE	Q	30	12400	15400	18800	22800	27400	32500	38500
		40	10900	13300	16100	19400	23300	27800	33000
		50		11200	13200	15700	18700	22200	26400
	P	30	5800	5900	6000	6050	6150	6250	6400
		40	7250	7300	7400	7450	7500	7600	7700
		50		9150	9200	9250	9250	9300	9400
ZB92KCE	Q	30	14800	18200	22100	26600	32000	38000	44500
		40	12900	15800	19100	23000	27500	32500	38500
		50		13250	16100	19300	23000	27400	32500
	P	30	7150	7350	7500	7700	7950	8250	8650
		40	8700	8950	9150	9350	9550	9800	10100
		50		10700	11000	11300	11500	11700	12000
ZB11MCE	Q	30	18000	22100	26800	32500	39000	46000	54500
		40	15500	19100	23300	28100	33500	40000	47500
		50		15900	19500	23500	28200	33500	40000
	P	30	8650	8800	9000	9150	9400	9700	10100
		40	10500	10800	11000	11200	11400	11600	11900
		50		13000	13300	13600	13800	14000	14200

* Capacity based on 20°C suction temp, no sub-cooling.

Performance Data

Q=Capacity (Watts) P=Power input (Watts)

50 Hz

Model	Con. Temp. °C	Evaporating Temperature °C						
		-15	-10	-5	0	5	10	
ZB15KQE	Q	35	1810	2360	2950	3600	4350	5300
		45	1540	1980	2570	3150	3850	4700
		55		1640	2110	2650	3350	4050
	P	35	750	730	720	710	710	740
		45	1060	1040	1020	1000	980	970
		55		1410	1390	1370	1340	1310
ZB19KQE	Q	35	1900	2560	3250	4100	5000	6050
		45	1670	2190	2900	3650	4500	5400
		55		1880	2450	3150	3950	4800
	P	35	1020	1020	1010	1000	990	980
		45	1280	1290	1290	1280	1270	1260
		55		1630	1630	1610	1600	1580
ZB21KQE	Q	35	2580	3400	4200	5150	6300	7550
		45	2270	2900	3800	4650	5650	6800
		55		2510	3200	4000	5000	6000
	P	35	1180	1190	1190	1200	1210	1230
		45	1450	1470	1480	1490	1500	1510
		55		1810	1830	1840	1850	1870
ZB26KQE	Q	35	2690	3600	4550	5600	6800	8150
		45	2280	3000	4000	5000	6100	7350
		55		2550	3350	4250	5400	6550
	P	35	1360	1340	1330	1320	1320	1310
		45	1770	1730	1710	1690	1690	1680
		55		2210	2160	2130	2120	2110
ZB30KQE	Q	35	3500	4600	5750	7050	8550	10250
		45	3050	3950	5100	6300	7700	9250
		55		3350	4300	5400	6750	8150
	P	35	1630	1630	1630	1630	1630	1640
		45	2050	2050	2040	2030	2020	2020
		55		2570	2550	2540	2520	2520
ZB38KQE	Q	35	4300	5650	7050	8650	10550	12700
		45	3800	4900	6350	7800	9500	11450
		55		4250	5400	6750	8400	10150
	P	35	1900	1930	1950	1960	1980	2010
		45	2350	2380	2400	2420	2450	2480
		55		2960	2980	2990	3010	3050
ZB45KQE	Q	35	5200	6800	8450	10400	12650	15200
		45	4500	5750	7500	9250	11300	13650
		55		4900	6250	7850	9850	11950
	P	35	2280	2280	2290	2300	2320	2350
		45	2900	2880	2880	2890	2900	2920
		55		3660	3640	3630	3630	3630

* Capacity based on 20°C suction temp, no sub-cooling.

*  Max suction superheat is 11K.

Performance Data

Q=Capacity (Watts) P=Power input (Watts)

50 Hz

Model	Con. Temp. °C	Evaporating Temperature °C						
		-15	-10	-5	0	5	10	
ZB50KQE	Q	35	6200	7800	9650	11800	14250	17100
		45	5550	6950	8650	10600	12850	15400
		55		6100	7600	9300	11300	13600
	P	35	2690	2710	2750	2800	2840	2840
		45	3320	3350	3400	3440	3470	3460
		55		4090	4150	4210	4240	4230
ZB58KQE	Q	35	6950	8750	10850	13250	16000	19200
		45	6200	7800	9700	11900	14400	17300
		55		6850	8500	10450	12700	15300
	P	35	3010	3030	3070	3130	3180	3190
		45	3720	3750	3800	3850	3890	3880
		55		4590	4660	4720	4760	4750
ZB66KQE	Q	35	8000	10000	12400	15200	18400	22000
		45	7100	8900	11050	13600	16500	19800
		55		7800	9700	11950	14550	17500
	P	35	3360	3380	3430	3490	3540	3560
		45	4150	4190	4250	4300	4340	4340
		55		5100	5200	5300	5300	5300
ZB76KQE	Q	35	9150	11450	14200	17400	21100	25200
		45	8150	10200	12650	15600	18900	22700
		55		8950	11100	13650	16600	20000
	P	35	3940	3960	4020	4100	4150	4160
		45	4870	4900	4970	5050	5100	5050
		55		6000	6100	6150	6200	6200
ZB92KQE	Q	35	10750	13800	17000	20700	25000	30000
		45	9400	11850	15200	18500	22400	26800
		55		10250	12850	15900	19700	23600
	P	35	4520	4650	4780	4940	5150	5400
		45	5600	5750	5900	6100	6250	6450
		55		7050	7250	7450	7600	7800
ZB11MCE	Q	35	13150	16900	20700	25200	30500	36500
		45	11500	14450	18500	22500	27300	32500
		55		12400	15600	19300	23900	28800
	P	35	5400	5550	5700	5850	6050	6350
		45	6750	6950	7100	7250	7450	7650
		55		8500	8750	8950	9150	9300

* Capacity based on 20°C suction temp, no sub-cooling.

*  Max suction superheat is 11K.

Performance Data

Q=Capacity (Watts) P=Power input (Watts) 3-Phase

60 Hz

Model	Con. Temp. °C	Evaporating Temperature °C					
		-10	-5	0	5	10	
ZB15KQ	Q	30	4450	5500	6700	8050	9600
		40	4000	5000	6050	7300	8750
		50	3150	3900	4800	5850	7050
	P	30	1320	1300	1290	1270	1240
		40	1720	1680	1660	1630	1610
		50	2240	2180	2130	2090	2060
ZB19KQ	Q	30	5300	6450	7800	9300	11050
		40	4800	5850	7100	8550	10150
		50	4200	5200	6350	7650	9150
	P	30	1550	1530	1510	1490	1470
		40	1960	1940	1910	1890	1870
		50	2480	2450	2420	2390	2360
ZB21KQ	Q	30	6750	8250	9950	11900	14050
		40	6100	7500	9100	10850	12850
		50	5400	6700	8150	9800	11600
	P	30	1880	1870	1850	1830	1820
		40	2390	2370	2350	2340	2330
		50	3030	3000	2970	2950	2930
ZB26KQ	Q	30	7750	9500	11500	13750	16300
		40	7000	8600	10500	12600	15000
		50	6100	7650	9350	11350	13550
	P	30	2170	2160	2150	2130	2120
		40	2760	2740	2720	2700	2670
		50	3480	3460	3440	3400	3360
ZB30KQ	Q	30	9000	11000	13250	15800	18700
		40	8650	10550	12700	15200	17900
		50	7300	8950	10850	13050	15500
	P	30	2540	2580	2620	2680	2770
		40	3110	3140	3180	3230	3300
		50	3800	3840	3880	3930	4000
ZB38KQ	Q	30	11050	13700	16700	20200	24200
		40	9900	12400	15200	18400	22000
		50	8450	10800	13450	16400	19800
	P	30	3120	3120	3130	3140	3150
		40	3940	3910	3890	3880	3870
		50	5000	4930	4880	4840	4820
ZB45KQ	Q	30	13500	16400	19700	23500	28000
		40	12300	14950	18000	21500	25500
		50	11000	13500	16300	19500	23100
	P	30	3640	3690	3730	3740	3710
		40	4480	4540	4600	4650	4680
		50	5550	5600	5650	5700	5750

* Capacity based on 20°C suction temp, no sub-cooling.

*  Max suction superheat is 11K.

Performance Data

Q=Capacity (Watts) P=Power input (Watts) 3-Phase

60 Hz

Model	Con. Temp. °C	Evaporating Temperature °C					
		-10	-5	0	5	10	
ZB50KQ	Q	30	15600	18900	22800	27300	32500
		40	14050	17300	20900	25100	29900
		50	12150	15300	18800	22700	27100
	P	30	4170	4240	4320	4420	4540
		40	5200	5250	5300	5400	5450
		50	6550	6550	6600	6600	6650
ZB58KQ	Q	30	17700	21500	25900	31000	36500
		40	16000	19600	23700	28400	33500
		50	14000	17400	21200	25600	30500
	P	30	4910	4970	5050	5150	5350
		40	6050	6050	6100	6150	6250
		50	7450	7450	7450	7450	7550
ZB66KQ	Q	30	20000	24200	29100	34500	41000
		40	18300	22200	26800	32000	38000
		50	16400	20000	24200	28900	34500
	P	30	5400	5550	5650	5800	6000
		40	6650	6750	6850	6950	7100
		50	8100	8200	8300	8400	8500
ZB76KQ	Q	30	23900	28900	34500	41000	48000
		40	21900	26500	32000	37500	44500
		50	19600	23900	28700	34000	40000
	P	30	6400	6500	6650	6850	7100
		40	7850	7950	8050	8200	8400
		50	9700	9800	9850	9950	10100
ZB88KQ	Q	30	27800	34500	41500	48500	55000
		40	24200	30000	36500	43500	50000
		50	21400	26400	32500	39000	45500
	P	30	7250	7400	7600	7850	8200
		40	8850	9000	9150	9300	9550
		50	10800	11000	11100	11200	11400
ZB92KC*	Q	30	27900	34000	41000	49500	59000
		40	25700	31500	38000	45500	54000
		50	22700	28100	34000	41000	48500
	P	30	8500	8550	8650	8750	8950
		40	10200	10300	10300	10300	10400
		50	12300	12400	12400	12400	12400
ZB11MC*	Q	30	35000	42500	51000	60500	71500
		40	32000	38500	46500	55500	66000
		50	28800	35000	42000	50500	60000
	P	30	9800	9900	9950	10100	10400
		40	12100	12200	12200	12300	12400
		50	14700	14900	15000	15000	15100

* *TWD Models

* Capacity based on 20°C suction temp, no sub-cooling.

* Max suction superheat is 11K.

Performance Data

Q=Capacity (Watts) P=Power input (Watts) 1-Phase

60 Hz

Model	Con. Temp. °C	Evaporating Temperature °C					
		-10	-5	0	5	10	
ZB15KQ	Q	30	4250	5300	6450	7750	9200
		40	3850	4800	5850	7100	8450
		50	3400	4250	5250	6350	7650
	P	30	1270	1260	1260	1250	1250
		40	1600	1600	1590	1590	1580
		50	2050	2030	2010	1990	1980
ZB19KQ	Q	30	5150	6300	7650	9250	11200
		40	4750	5800	7000	8400	10000
		50	4100	5150	6300	7550	9000
	P	30	1560	1540	1520	1510	1530
		40	1980	1920	1880	1860	1860
		50	2580	2480	2390	2330	2290
ZB21KQ	Q	30	6800	8250	9900	11800	14000
		40	6150	7500	9050	10850	12850
		50	5500	6700	8150	9750	11650
	P	30	1960	1940	1920	1920	1940
		40	2460	2430	2400	2380	2370
		50	3090	3070	3030	2990	2950
ZB26KQ	Q	30	7800	9500	11500	13750	16400
		40	7050	8700	10550	12600	15000
		50	6100	7700	9400	11350	13500
	P	30	2280	2260	2250	2240	2230
		40	2830	2810	2790	2770	2750
		50	3540	3510	3480	3440	3410
ZB30KQ	Q	30	9150	11150	13400	15900	18600
		40	8250	10100	12250	14600	17200
		50	7300	9000	10950	13150	15500
	P	30	2750	2800	2850	2920	3010
		40	3300	3350	3390	3450	3510
		50	3970	4030	4080	4120	4170
ZB38KQ	Q	30	10650	13250	16200	19400	23000
		40	9600	12100	14900	18100	21700
		50	8550	10750	13400	16400	19800
	P	30	3340	3410	3490	3590	3710
		40	4010	4070	4140	4210	4300
		50	4840	4910	4970	5050	5100

* Capacity based on 20°C suction temp, no sub-cooling.

* Max suction superheat is 11K.

Performance Data

Q=Capacity (Watts) P=Power input (Watts) 3-Phase

60 Hz

Model	Con. Temp. °C	Evaporating Temperature °C							
		-23	-20	-15	-10	-5	0	5	
ZB15KQ	Q	30	3050	3500	4300	5200	6300	7550	8950
		40	2555	2950	3650	4500	5400	6500	7700
		50		2345	3000	3700	4450	5350	6400
	P	30	1540	1530	1530	1510	1500	1470	1440
		40	1950	1950	1940	1920	1910	1880	1850
		50		2480	2470	2450	2420	2390	2360
ZB19KQ	Q	30	3900	4400	5350	6500	7750	9250	10900
		40	3350	3800	4650	5650	6750	8000	9450
		50		3150	3900	4700	5650	6750	7950
	P	30	1760	1760	1780	1780	1790	1790	1780
		40	2210	2210	2220	2230	2230	2230	2220
		50		2770	2780	2790	2790	2790	2780
ZB21KQ	Q	30	4650	5300	6450	7800	9350	11100	13050
		40	4050	4600	5600	6750	8100	9650	11350
		50		3800	4650	5650	6800	8100	9550
	P	30	2110	2120	2130	2140	2150	2140	2130
		40	2650	2650	2670	2680	2680	2680	2670
		50		3330	3340	3340	3350	3340	3330
ZB26KQ	Q	30	5450	6150	7500	9100	10900	12950	15200
		40	4700	5350	6500	7900	9450	11200	13250
		50		4450	5450	6600	7900	9400	11150
	P	30	2460	2470	2490	2500	2510	2500	2490
		40	3090	3100	3120	3130	3130	3130	3120
		50		3890	3900	3910	3910	3910	3900
ZB30KQ	Q	30	6200	7050	8600	10400	12500	14800	17500
		40	5400	6100	7450	9050	10850	12850	15200
		50		5100	6250	7550	9050	10800	12750
	P	30	2770	2780	2800	2810	2820	2820	2800
		40	3480	3490	3510	3520	3530	3520	3510
		50		4370	4390	4400	4400	4400	4380
ZB38KQ	Q	30	7750	8800	10750	13000	15600	18500	21800
		40	6750	7650	9350	11300	13500	16100	18900
		50		6350	7800	9450	11350	13500	15900
	P	30	3460	3480	3500	3520	3530	3520	3500
		40	4350	4360	4380	4400	4410	4400	4390
		50		5450	5500	5500	5500	5500	5500
ZB45KQ	Q	30	9200	10450	12750	15400	18500	22000	25900
		40	8000	9050	11100	13400	16000	19100	22500
		50		7550	9250	11200	13450	16000	18900
	P	30	4040	4060	4090	4110	4120	4110	4090
		40	5100	5100	5100	5150	5150	5150	5100
		50		6400	6400	6400	6400	6400	6400

* Capacity based on 20°C suction temp, no sub-cooling.

Performance Data

Q=Capacity (Watts) P=Power input (Watts) 3-Phase

60 Hz

Model	Con. Temp. °C	Evaporating Temperature °C							
		-23	-20	-15	-10	-5	0	5	
ZB50KQ	Q	30	10550	12050	14850	18000	21600	25700	30500
		40	8750	10150	12700	15500	18700	22300	26400
		50		7950	10200	12700	15400	18500	22100
	P	30	4940	4970	5000	5100	5150	5200	5250
		40	6200	6200	6200	6250	6300	6300	6350
		50		7850	7750	7750	7700	7700	7750
ZB58KQ	Q	30		13750	20800	25100	29900	35500	
		40		11450	17600	21400	25500	30000	
		50		8850	14100	17200	20600	24500	
	P	30		5500	5650	5750	5850	5900	
		40		6900	6950	7000	7050	7150	
		50		8700	8600	8600	8650	8650	
ZB66KQ	Q	30	13600	15400	18800	22800	27400	32500	38500
		40	11800	13450	16400	19900	23800	28300	33500
		50	11200	13800	16700	20000	23700	27900	
	P	30	6050	6150	6250	6400	6550	6700	6850
		40	7450	7500	7650	7750	7900	8000	8100
		50		9250	9350	9450	9550	9650	9750
ZB76KQ*	Q	30	15800	17800	21600	26000	31000	37000	43500
		40	13750	15500	18900	22700	27200	32500	38000
		50		13050	15900	19200	22900	27200	32000
	P	30	6800	6950	7250	7550	7950	8450	9050
		40	8150	8300	8600	8900	9200	9600	10000
		50		9950	10300	10600	10900	11200	11500
ZB92KC*	Q	30	19300	21700	26300	31500	38000	45500	54500
		40	17000	19200	23300	27900	33500	39500	47000
		50		16300	19900	23800	28200	33500	39000
	P	30	8700	8900	9200	9600	10000	10500	11100
		40	10500	10700	11000	11400	11700	12200	12600
		50		12900	13300	13600	14000	14300	14700
ZB11MC*	Q	30	23300	26400	32000	38500	46000	54500	64500
		40	20200	23000	28000	33500	40000	47500	56000
		50		19200	23600	28300	33500	40000	47000
	P	30	10600	10700	11000	11200	11600	12000	12500
		40	12800	13000	13200	13500	13800	14200	14700
		50		15800	16100	16400	16700	17000	17500

* *TWD Models

* Capacity based on 20°C suction temp, no sub-cooling.

Performance Data

Q=Capacity (Watts) P=Power input (Watts) 1-Phase

60 Hz

Model	Con. Temp. °C	Evaporating Temperature °C							
		-23	-20	-15	-10	-5	0	5	
ZB15KQ	Q	30	3150	3550	4350	5250	6250	7450	8800
		40	2710	3100	3750	4550	5450	6450	7650
		50		2555	3150	3800	4550	5450	6400
	P	30	1460	1470	1480	1490	1490	1490	1480
		40	1840	1840	1850	1860	1860	1860	1850
		50		2310	2320	2320	2320	2320	2320
ZB19KQ	Q	30	3900	4450	5400	6550	7850	9300	10950
		40	3400	3850	4700	5650	6800	8100	9550
		50		3200	3900	4750	5700	6800	8000
	P	30	1830	1840	1850	1860	1860	1860	1850
		40	2300	2300	2310	2320	2330	2320	2320
		50		2890	2890	2900	2900	2900	2890
ZB21KQ	Q	30	4650	5300	6450	7800	9350	11150	13100
		40	4050	4600	5600	6800	8150	9650	11400
		50		3800	4700	5650	6800	8100	9600
	P	30	2190	2200	2220	2230	2230	2230	2220
		40	2750	2760	2780	2790	2790	2790	2780
		50		3460	3470	3480	3480	3480	3470
ZB26KQ	Q	30	5450	6200	7550	9150	10950	13000	15300
		40	4750	5350	6550	7950	9500	11300	13300
		50		4450	5450	6650	7950	9500	11200
	P	30	2560	2570	2590	2600	2610	2600	2590
		40	3210	3220	3240	3250	3260	3260	3240
		50		4040	4050	4060	4070	4060	4050
ZB30KQ	Q	30	6100	6950	8600	10450	12550	15000	17700
		40	5200	5950	7400	9050	10900	13000	15400
		50		4850	6100	7500	9100	10850	12900
	P	30	3060	3080	3100	3130	3170	3220	3280
		40	3720	3740	3760	3790	3820	3850	3890
		50		4550	4580	4600	4630	4650	4690
ZB38KQ	Q	30	7600	8700	10750	13100	15700	18600	21700
		40	6400	7350	9200	11250	13600	16200	19100
		50		6000	7500	9250	11250	13550	16100
	P	30	3660	3680	3720	3770	3840	3950	4100
		40	4450	4480	4520	4560	4610	4690	4790
		50		5450	5500	5550	5600	5650	5750

* Capacity based on 20°C suction temp, no sub-cooling.

Performance Data

Q=Capacity (Watts) P=Power input (Watts) 3-Phase

60 Hz

Model	Con. Temp. °C	Evaporating Temperature °C						
		-15	-10	-5	0	5	10	
ZB15KQE	Q	30	2480	3000	3750	4600	5550	6650
		45	2075	2675	3200	4000	4850	5850
		55		2330	3000	3800	4300	5200
	P	30	893	906	920	936	955	978
		45	1210	1230	1250	1260	1280	1300
		55		1500	1520	1540	1560	1580
ZB19KQE	Q	30	2860	3450	4300	5300	6450	7700
		45	2390	3100	3700	4600	5600	6750
		55		2690	3450	4400	5000	6000
	P	30	1040	1050	1070	1090	1110	1140
		45	1410	1430	1450	1470	1490	1510
		55		1740	1770	1800	1820	1840
ZB21KQE	Q	30	3600	4350	5450	6700	8100	9700
		45	3000	3900	4650	5800	7050	8500
		55		3400	4350	5500	6300	7600
	P	30	1270	1290	1310	1330	1360	1390
		45	1720	1750	1770	1800	1820	1840
		55		2130	2160	2190	2220	2240
ZB26KQE	Q	30	4150	5050	6250	7700	9350	11200
		45	3500	4500	5400	6700	8150	9800
		55		3900	5050	6400	7250	8750
	P	30	1440	1460	1490	1510	1540	1580
		45	1950	1990	2020	2040	2070	2100
		55		2420	2460	2500	2530	2550
ZB30KQE	Q	30	4900	5900	7350	9050	11000	13150
		45	4100	5300	6350	7850	9600	11500
		55		4600	5950	7500	8550	10300
	P	30	1710	1730	1760	1790	1830	1870
		45	2310	2350	2390	2420	2450	2480
		55		2870	2920	2960	2990	3020
ZB38KQE	Q	30	6000	7250	9050	11150	13550	16200
		45	5050	6500	7800	9650	11800	14150
		55		5650	7300	9200	10500	12650
	P	30	2120	2150	2190	2230	2270	2330
		45	2870	2920	2960	3000	3040	3080
		55		3560	3620	3670	3710	3750
ZB45KQE	Q	30	7300	8800	10900	13400	16200	19400
		45	6000	7750	9250	11400	13900	16700
		55		6650	8500	10700	12150	14700
	P	30	2440	2480	2510	2540	2590	2660
		45	3360	3400	3430	3460	3490	3530
		55		4210	4250	4280	4300	4330

* Capacity based on 20°C suction temp, no sub-cooling.

*  Max suction superheat is 11K.

Performance Data

Q=Capacity (Watts) P=Power input (Watts) 3-Phase

60 Hz

Model	Con. Temp. °C	Evaporating Temperature °C						
		-15	-10	-5	0	5	10	
ZB50KQE	Q	30	8400	10050	12400	15100	18100	21600
		45	7050	8950	10550	12900	15600	18600
		55		7800	9850	12200	13750	16500
	P	30	2860	2880	2960	3060	3180	3290
		45	3920	3980	4060	4150	4230	4290
		55		4900	5000	5100	5200	5250
ZB58KQE	Q	30	9400	11250	13900	17000	20400	24300
		45	7900	10000	11850	14500	17500	21000
		55		8750	11000	13650	15400	18500
	P	30	3200	3220	3300	3420	3540	3640
		45	4380	4430	4510	4610	4700	4760
		55		5450	5550	5650	5750	5800
ZB66KQE	Q	30	10650	12700	15700	19100	23000	27400
		45	8950	11300	13400	16400	19900	23700
		55		9850	12450	15500	17500	21000
	P	30	3590	3620	3710	3840	3980	4110
		45	4890	4970	5050	5200	5300	5350
		55		6100	6250	6350	6500	6550
ZB76KQE	Q	30	12300	14650	18000	22000	26500	31500
		45	10350	13100	15400	18900	22900	27300
		55		11400	14400	17900	20200	24100
	P	30	4230	4270	4370	4520	4680	4830
		45	5800	5850	6000	6100	6250	6300
		55		7200	7350	7500	7600	7650
ZB92KCE*	Q	30	15300	18100	22300	27100	33000	39000
		45	13100	16300	19100	23400	28300	34000
		55		14400	18000	22200	25000	30000
	P	30	5350	5600	5850	6200	6600	7100
		45	7050	7300	7500	7750	8050	8400
		55		8750	9000	9250	9500	9800
ZB11MCE*	Q	30	18500	21700	26700	32500	39000	46500
		45	15700	19600	23000	28200	34000	40500
		55		16300	20200	24800	30000	36000
	P	30	6550	6700	6900	7150	7650	8350
		45	8600	8900	9050	9250	9500	9900
		55		10600	10900	11100	11300	11600

* *TWD Models

* Capacity based on 20°C suction temp, no sub-cooling.

* Max suction superheat is 11K.

Performance Data

Q=Capacity (Watts) P=Power input (Watts) 1-Phase

60 Hz

Model	Con. Temp. °C	Evaporating Temperature °C						
		-15	-10	-5	0	5	10	
ZB15KQE	Q	30	2435	2950	3700	4500	5400	6450
		45	2040	2630	3150	3850	4700	5650
		55		2305	2900	3650	4150	5000
	P	30	966	976	991	1010	1040	1070
		45	1260	1270	1290	1310	1330	1350
		55		1530	1550	1570	1590	1620
ZB19KQE	Q	30	2810	3400	4250	5200	6250	7400
		45	2355	3050	3600	4450	5450	6550
		55		2660	3350	4200	4800	5800
	P	30	1210	1230	1240	1270	1300	1340
		45	1580	1600	1620	1640	1670	1700
		55		1930	1950	1980	2000	2030
ZB21KQE	Q	30	3550	4300	5350	6550	7850	9350
		45	2950	3850	4550	5650	6850	8250
		55		3350	4250	5300	6050	7300
	P	30	1500	1510	1540	1570	1610	1650
		45	1950	1980	2000	2030	2060	2100
		55		2380	2410	2440	2470	2500
ZB26KQE	Q	30	4100	5000	6200	7550	9100	10800
		45	3450	4400	5250	6500	7900	9500
		55		3850	4900	6100	6950	8450
	P	30	1810	1830	1860	1900	1950	2000
		45	2360	2390	2420	2460	2500	2540
		55		2880	2920	2960	3000	3040
ZB30KQE	Q	30	4800	5850	7300	8900	10700	12700
		45	4050	5200	6200	7650	9300	11200
		55		4550	5750	7200	8150	9900
	P	30	2010	2030	2060	2100	2150	2220
		45	2620	2650	2680	2720	2760	2810
		55		3190	3230	3270	3320	3360
ZB38KQE	Q	30	5900	7200	8950	10900	13150	15600
		45	4950	6400	7600	9400	11450	13750
		55		5600	7050	8850	10050	12200
	P	30	2340	2370	2410	2450	2510	2590
		45	3050	3090	3130	3180	3230	3280
		55		3720	3770	3820	3870	3920

* Capacity based on 20°C suction temp, no sub-cooling.

*  Max suction superheat is 11K.

Technical Data

Model	ZB15KQ ZB15KQE	ZB19KQ ZB19KQE	ZB21KQ ZB21KQE	ZB26KQ ZB26KQE	ZB30KQ ZB30KQE	ZB38KQ ZB38KQE	ZB45KQ ZB45KQE
Motor Type	TFD	TFD	TFD	TFD	TFD	TFD	TFD
	PFJ	PFJ	PFJ	PFJ			
Nominal power(HP)	2	2.5	3	3.5	4	5	6
Discharge Capacity(m ³ /hr)	5.92	6.8	8.6	9.9	11.68	14.5	17.2
Startup Current(LRA)(AMP)							
TFD	24.5~26	30~32	36~40	41~46	44.3~49.3	58.6~65.5	67~74
PFJ	53~58	56~61	75~82	89~97			
Rated Load Current(RLA)(AMP)							
TFD	4.30	4.30	5.70	7.10	7.40	8.90	11.50
PFJ	11.4	12.9	16.4	18.9			
Max Continuous Current(MCC)(AMP)							
TFD	6.0	6.0	8.0	10.0	10.4	12.5	16.1
PFJ	16	18	23	24			
Run Capacities (1 Phase)	40μF/370V	45μF/370V	50μF/370V	60μF/370V			
Crankcase Heater(W)	70	70	70	70	70	70	70
Connection Tube size(inch)							
Discharge Tube outer Diameter	1/2	1/2	1/2	1/2	1/2	1/2	1/2
Suction Tube outer Diameter	3/4	3/4	3/4	3/4	7/8	7/8	7/8
Dimension(mm)							
Length	242	242	243	243	242	242	242
Width	242	242	244	244	242	242	242
Height	383	389	412	425	457	457	457
Mounting pants installation size (hole size)	190X190 (8.5)	190X190 (8.5)	190X190 (8.5)	190X190 (8.5)	190X190 (8.5)	190X190 (8.5)	190X190 (8.5)
Oil Recharge(L)	1.18	1.45	1.45	1.45	1.89	1.89	1.89
Weight(kg)							
Net	23	25	27	28	37	38	40
Gross	26	29	30	31	40	41	44

ZB Series

Technical Data

Model	ZB50KQ ZB50KQE	ZB58KQ ZB58KQE	ZB66KQ ZB66KQE	ZB76KQ ZB76KQE	ZB88KQ	ZB92KC ZB92KCE	ZB11MC ZB11MCE
Motor Type	TFD	TFD	TFD	TFD	TFD	TWD	TWD
Nominal power(HP)	7.5	8	9	10	12	13	15
Discharge Capacity(m ³ /hr)	19.8	22.1	25.7	28.8	33.2	35.6	42.1
Startup Current(LRA)(AMP)	90~100	86~95	100~111	110~118	110~118	151~167	179~198
Rated Load Current(RLA)(AMP)	14.3	16.4	17.3	19.2	22.1	21.5	24.3
Max Continuous Current(MCC)(AMP)	20.0	23.0	24.2	26.9	31.0	30.1	34.0
Crankcase Heater(W)	90	90	90	90	90	70	70
Connection Tube size(inch)							
Discharge Tube outer Diameter	7/8	7/8	7/8	7/8	7/8	1 1/4	1 3/4
Suction Tube outer Diameter	1 1/8	1 1/8	1 3/8	1 3/8	1 3/8	1 3/4	2 1/4
Dimension(mm)							
Length	263.6	263.6	263.6	263.6	263.6	320.8	320.8
Width	284.2	284.2	284.2	284.2	284.2	357.1	349.2
Height	479.5	477	546.1	546.1	546.1	532.4	591.8
Mounting pants installation size (hole size)	190X190 (8.5)	190X190 (8.5)	190X190 (8.5)	190X190 (8.5)	190X190 (8.5)	220X220 (8.5)	220X220 (8.5)
Oil Recharge(L)	2.51	2.51	3.25	3.25	3.25	4.14	4.14
Weight(kg)							
Net	58.97	59.87	60.33	65.32	65.32	103	112
Gross						110	119

ZB Series

Dimensions

ZB15-ZB26 Brazing Connection

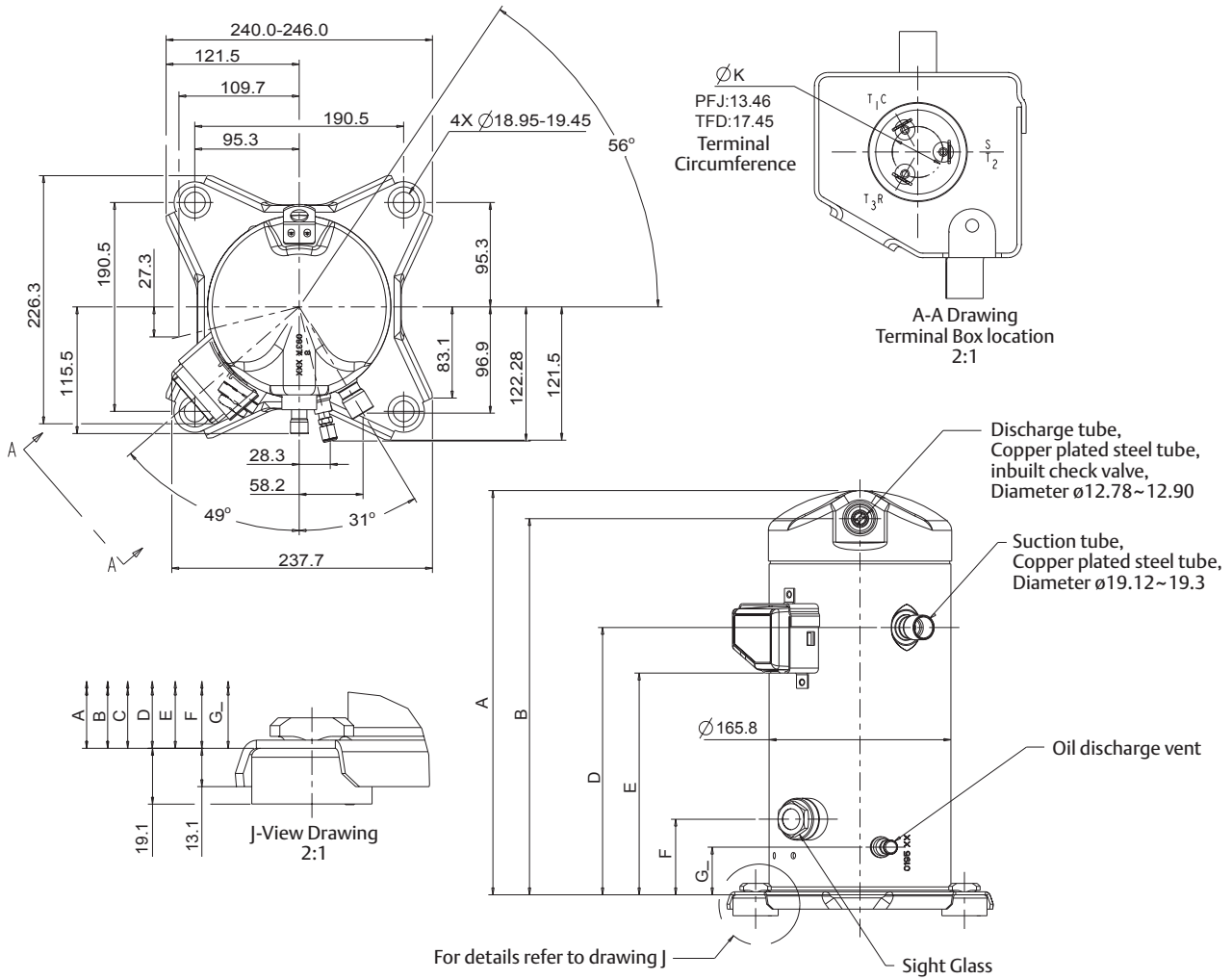

Compressor model	A ± 3	B ± 3	D ± 3	E ± 3	F ± 3	G ± 3
ZB15KQ/ZB15KQE	368.7	343.1	243.8	202.2	68.9	43.4
ZB19KQ/ZB19KQE						
ZB21KQ/ZB21KQE	391.3	365.7	263.7	222.1	74.6	49.1
ZB26KQ/ZB26KQE	405	379.4	276.4	234.8	74.6	49.1

ZB Series

Dimensions

ZB30-ZB45 Brazing Connection

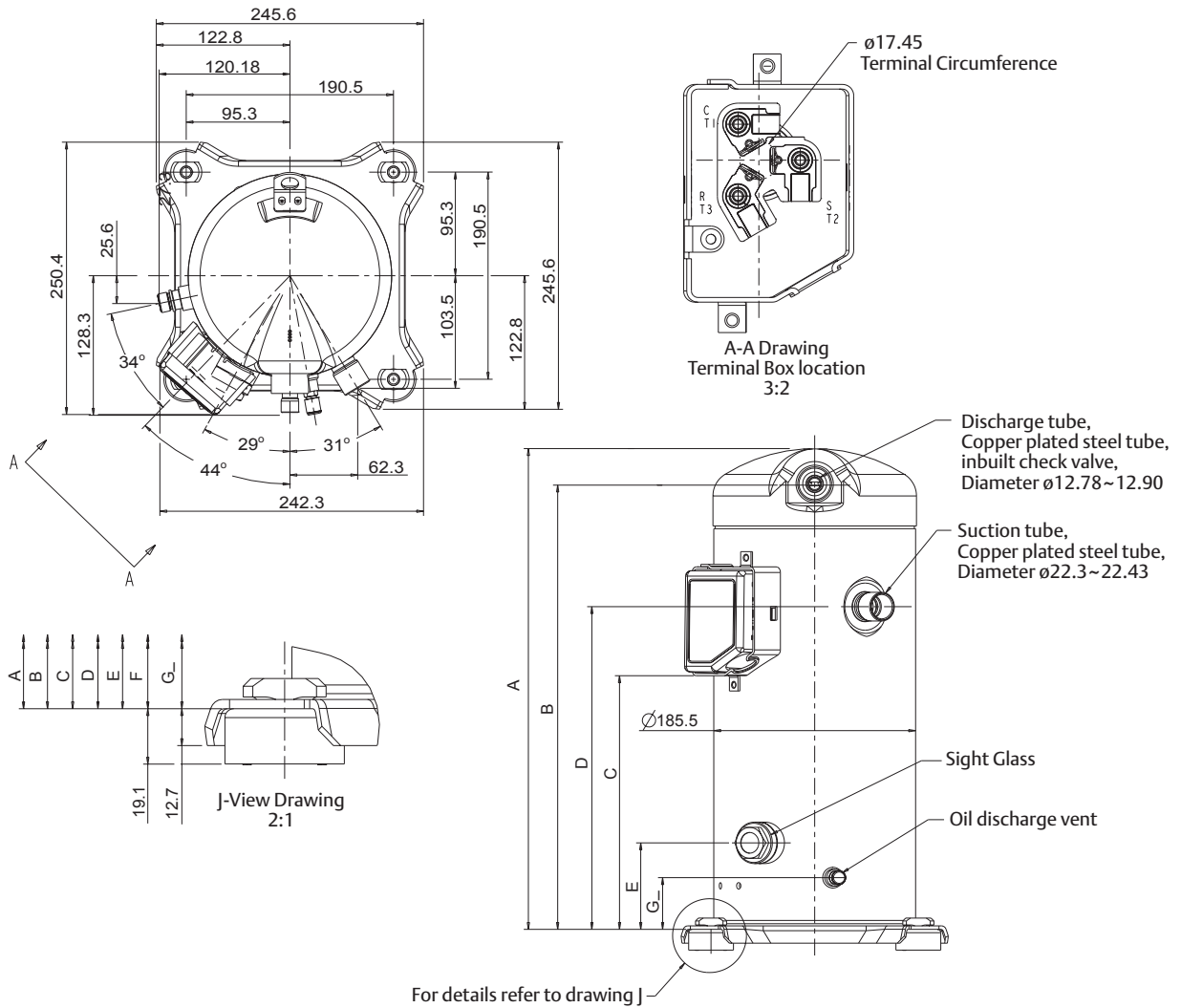

Compressor model	A ± 3	B	c ± 3	d ± 3	E	G ₋
ZB30KQ/ZB30KQE						
ZB38KQ/ZB38KQE	437.7	409.6	233.2	296.7	79.5	47.5
ZB45KQ/ZB45KQE						

ZB Series

Dimensions

ZB50-ZB58 Brazing Connection

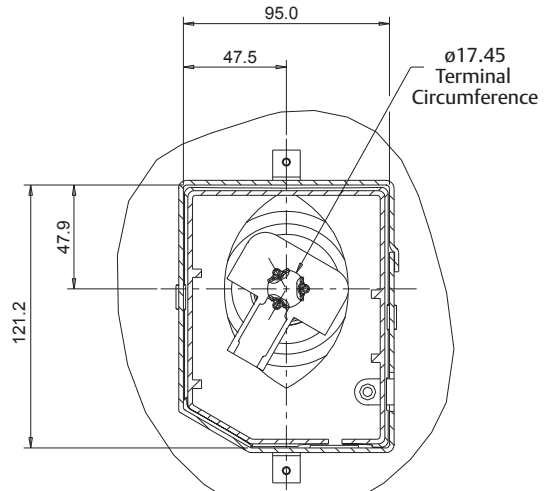
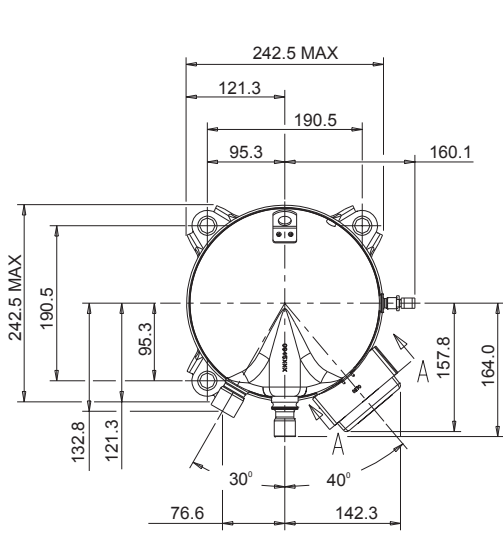

A-A Drawing
Terminal Box location
1:1

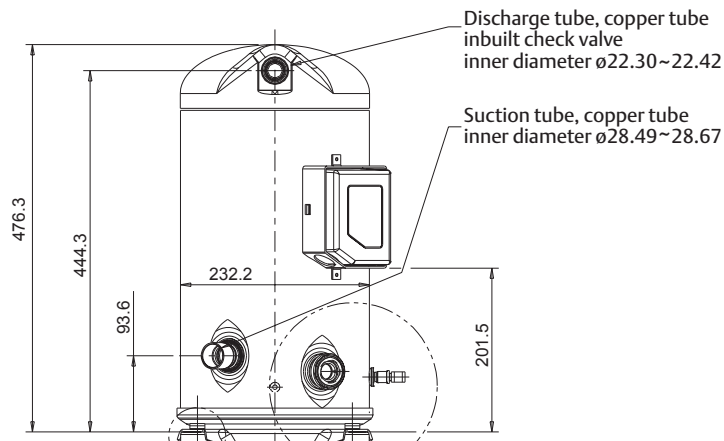

For details please refer to mounting drawing

For details refer to valve drawing

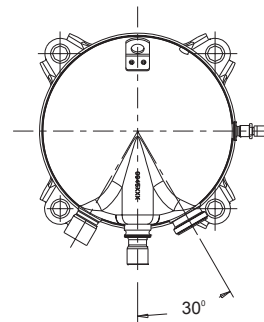

Sight glass layout
(Terminal box removed)

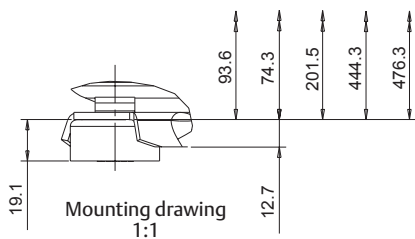

Mounting drawing
1:1

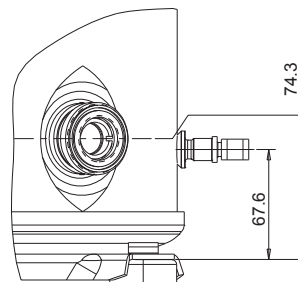

Valve drawing
3:4

ZB Series

Dimensions

ZB50-ZB58 Rotalock Connection

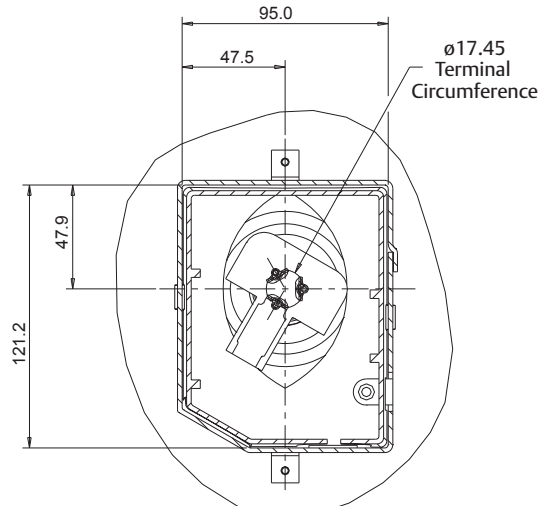
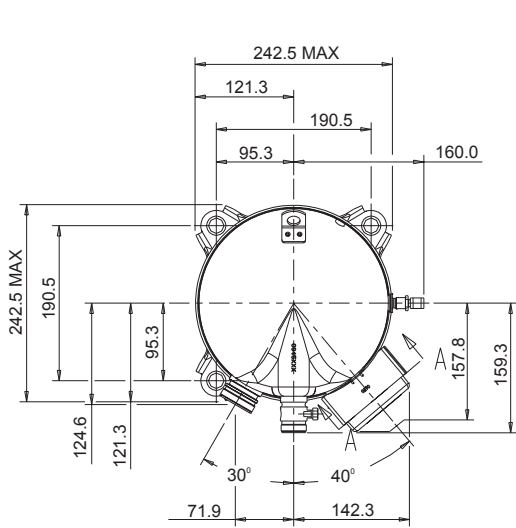

A-A Drawing
Terminal Box location
1:1

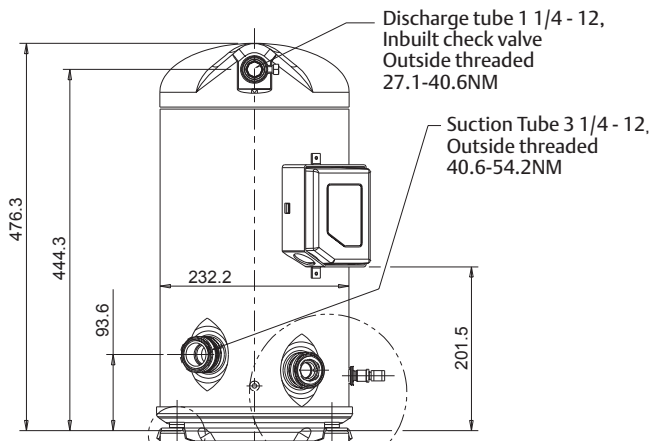

Discharge tube 1 1/4 - 12,
Inbuilt check valve
Outside threaded
27.1-40.6NM

Suction Tube 3 1/4 - 12,
Outside threaded
40.6-54.2NM

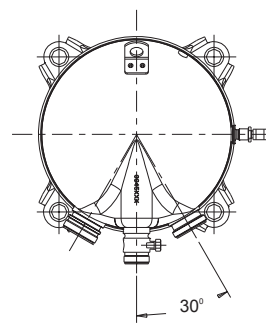

Sight glass layout
(Terminal box removed)

For details please refer to
mounting drawing

For details refer to
valve drawing

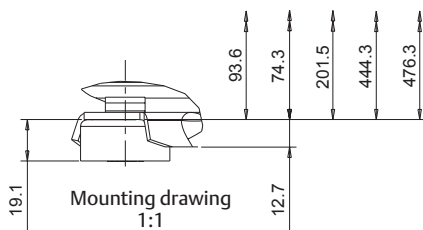

Mounting drawing
1:1

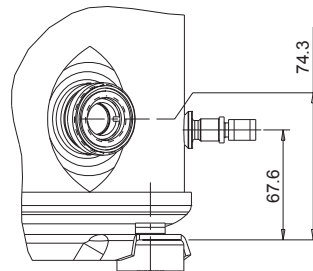

Valve drawing
3:4

ZB Series

Dimensions

ZB66-ZB88 Brazing Connection

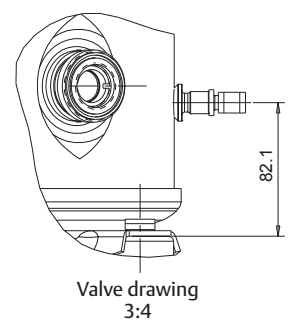
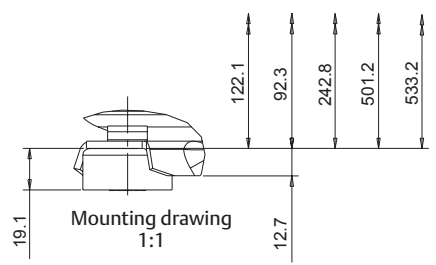
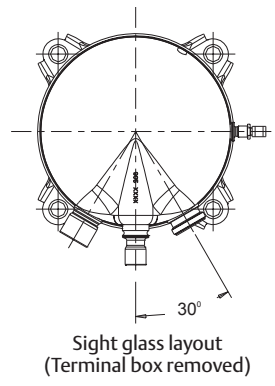
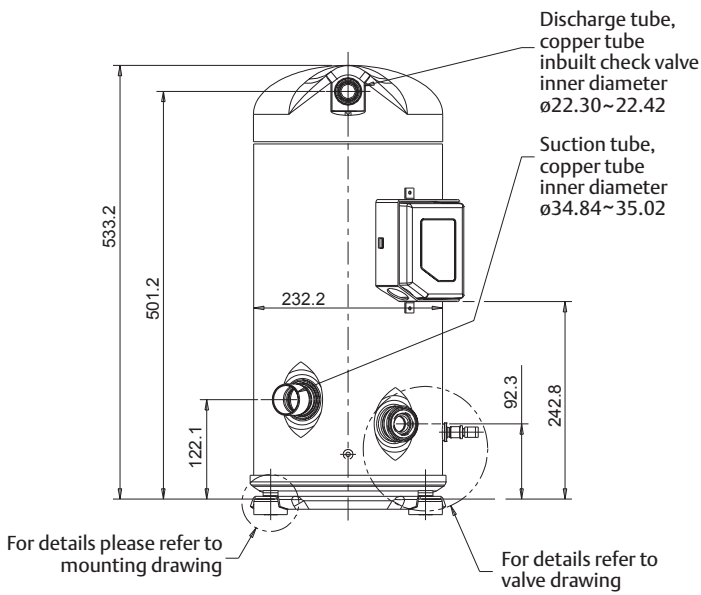
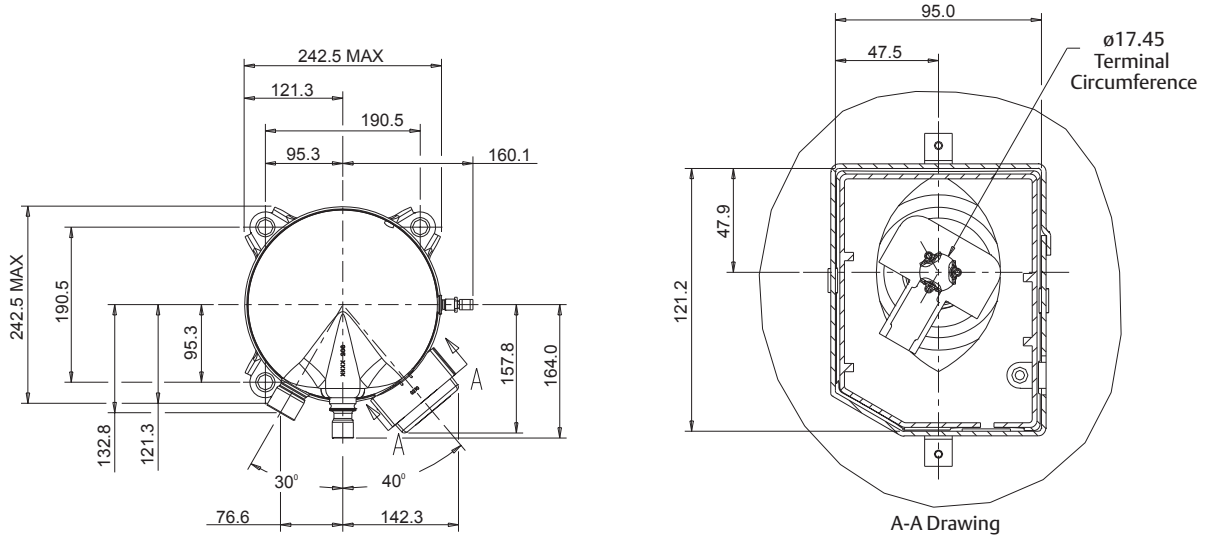

ZB Series

Dimensions

ZB66-ZB88 Rotalock Connection

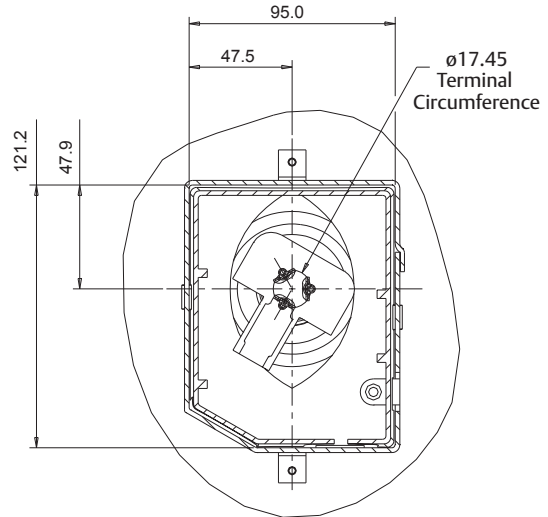
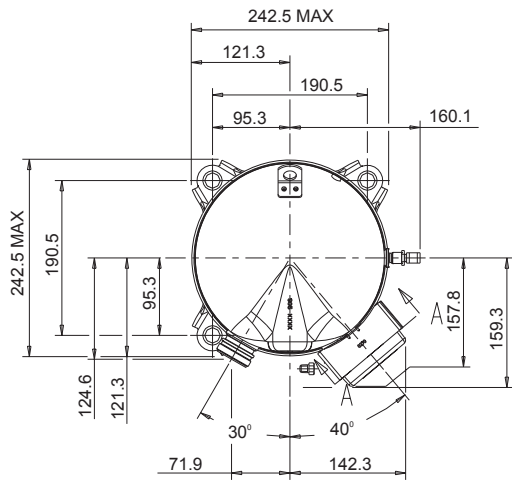

A-A Drawing
Terminal Box layout
1:1

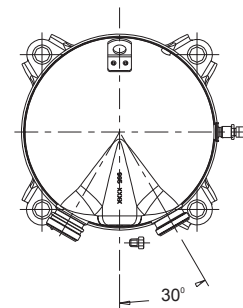
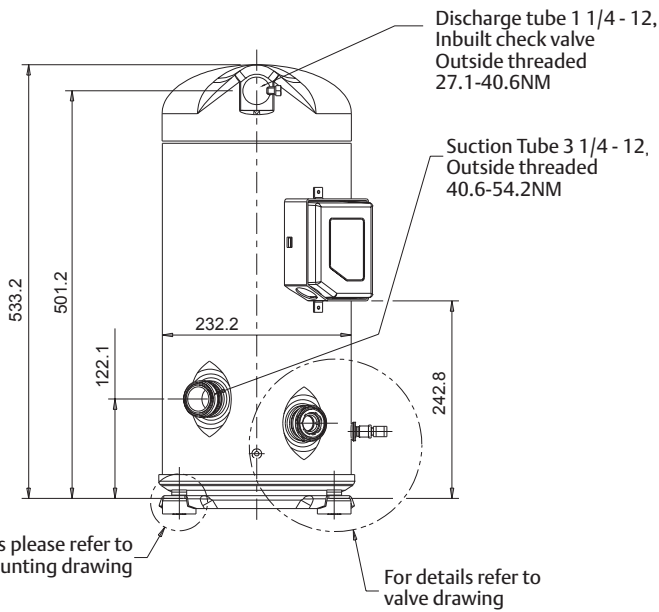

Sight glass layout
(Terminal box removed)

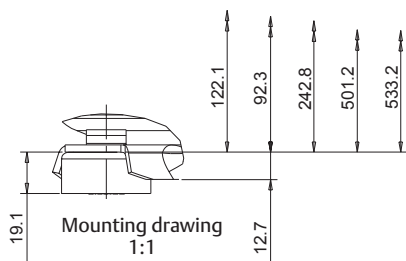

Mounting drawing
1:1

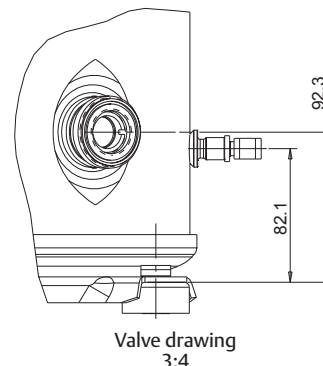

Valve drawing
3:4

ZB92 Rotalock Connection

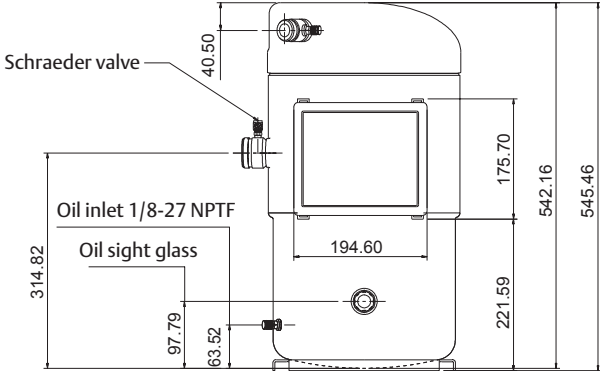
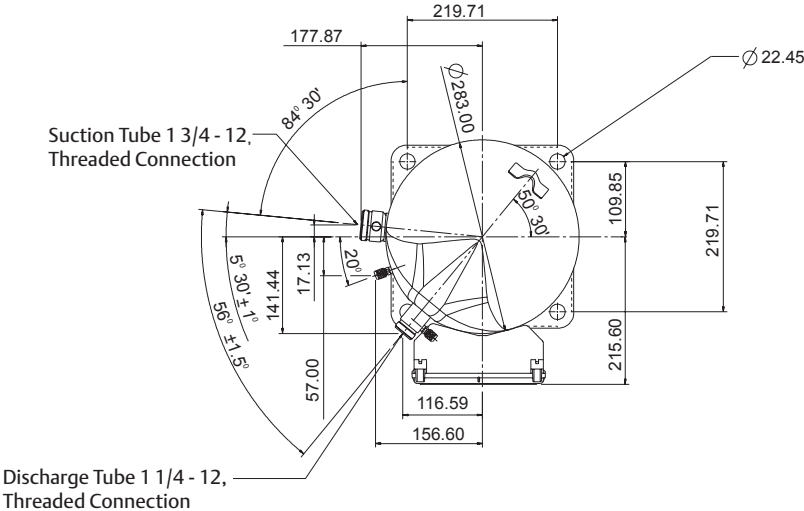

ZB Series

Dimensions

ZB11MC Rotalock Connection

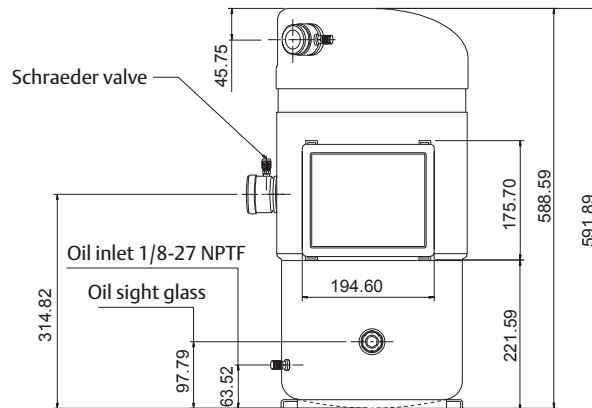
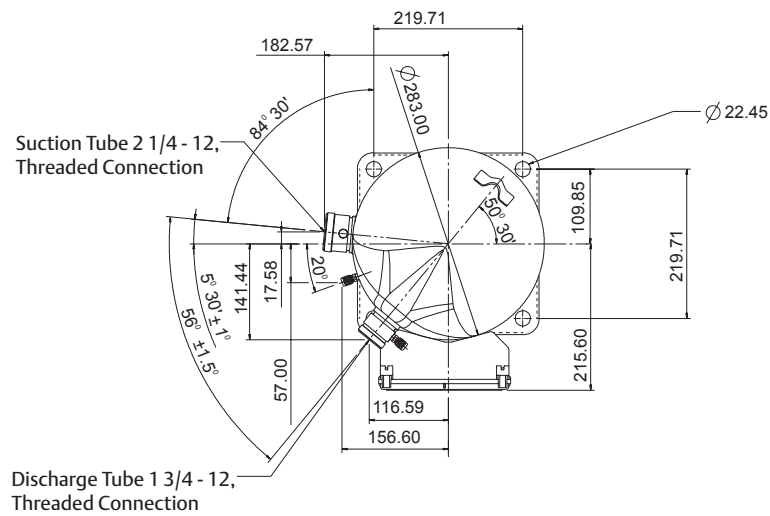

ZB Series

Electrical Wiring Diagram

ZB15-ZB88

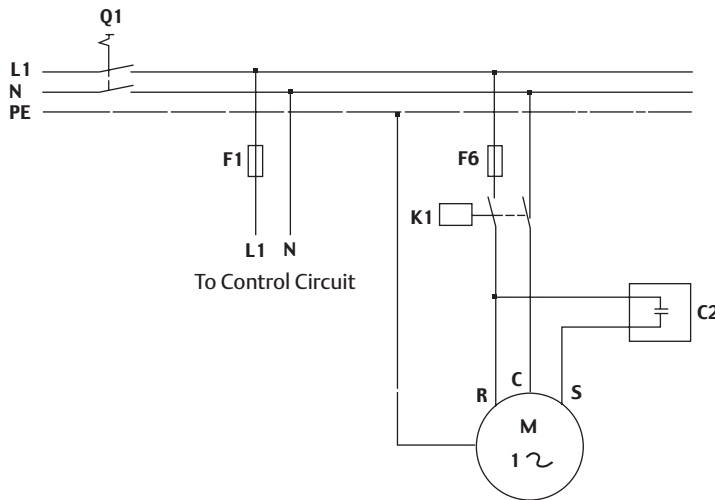

Single Phase Circuit (ZB15-ZB26)

Electrical Schematics

L1/N/PE: Single Phase Lines (line/neutral/ground)

Q1: Manual Switch

F1/F6: Fuse

K1: Compressor Contactor

C2: Run Capacitor

M: Compressor Motor

R/C/S: Compressor Terminal

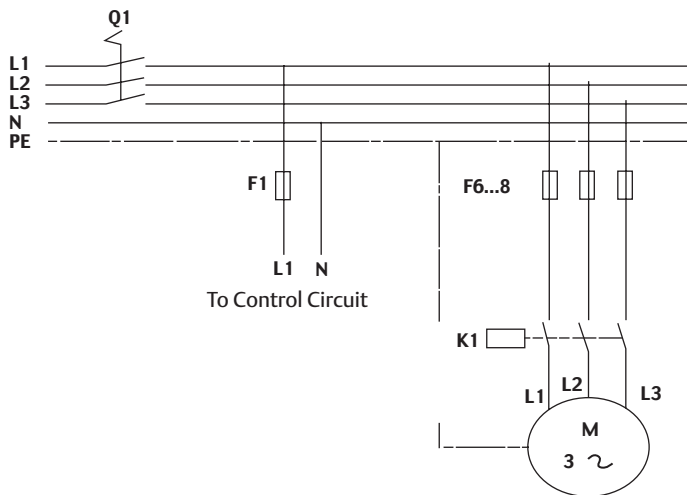

3 Phase (ZB15-ZB88)

Electrical Schematics

L1/L2/L3/N/PE: 3 Phase Lines (line/neutral/ground)

Q1: Manual Switch

F1/F6..8: Fuse

K1: Compressor Contactor

M: Compressor Motor

L1/L2/L3: Compressor Terminal

ZB Series

Electrical Wiring Diagram

ZB15-ZB88 Control Circuit

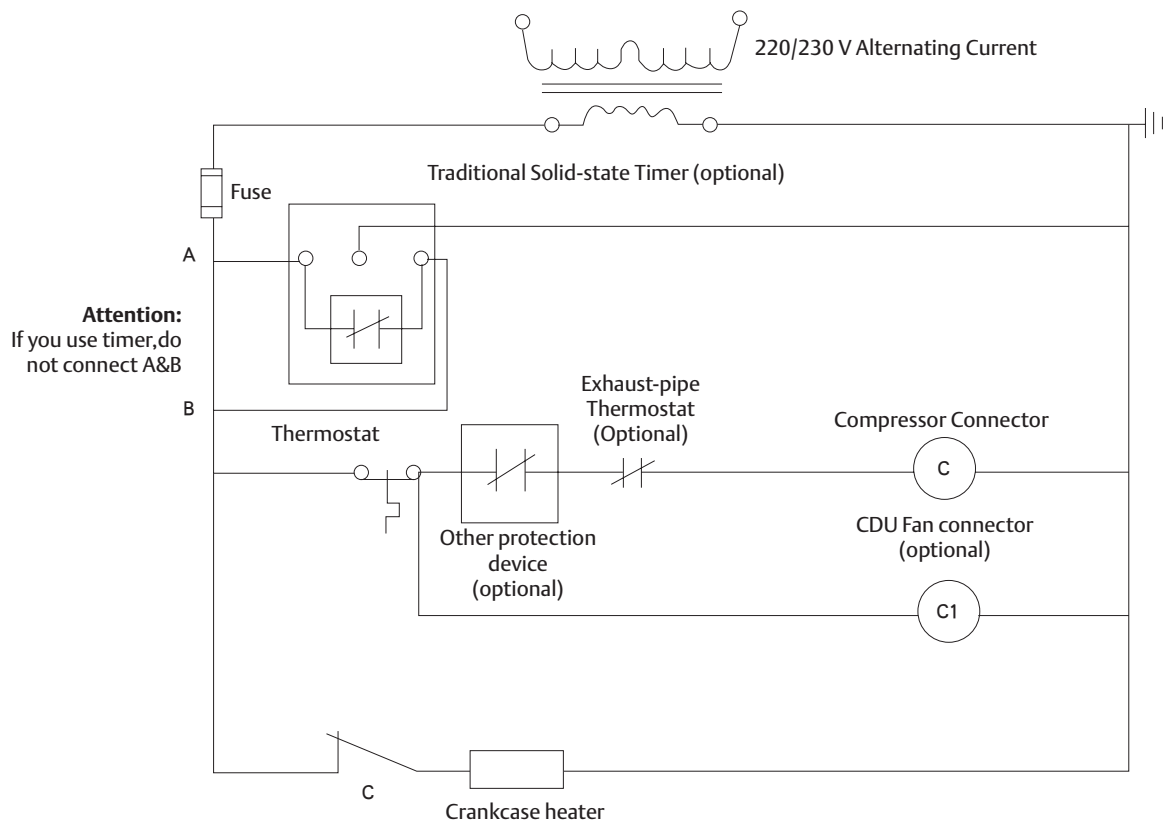

ZB92-ZB11M

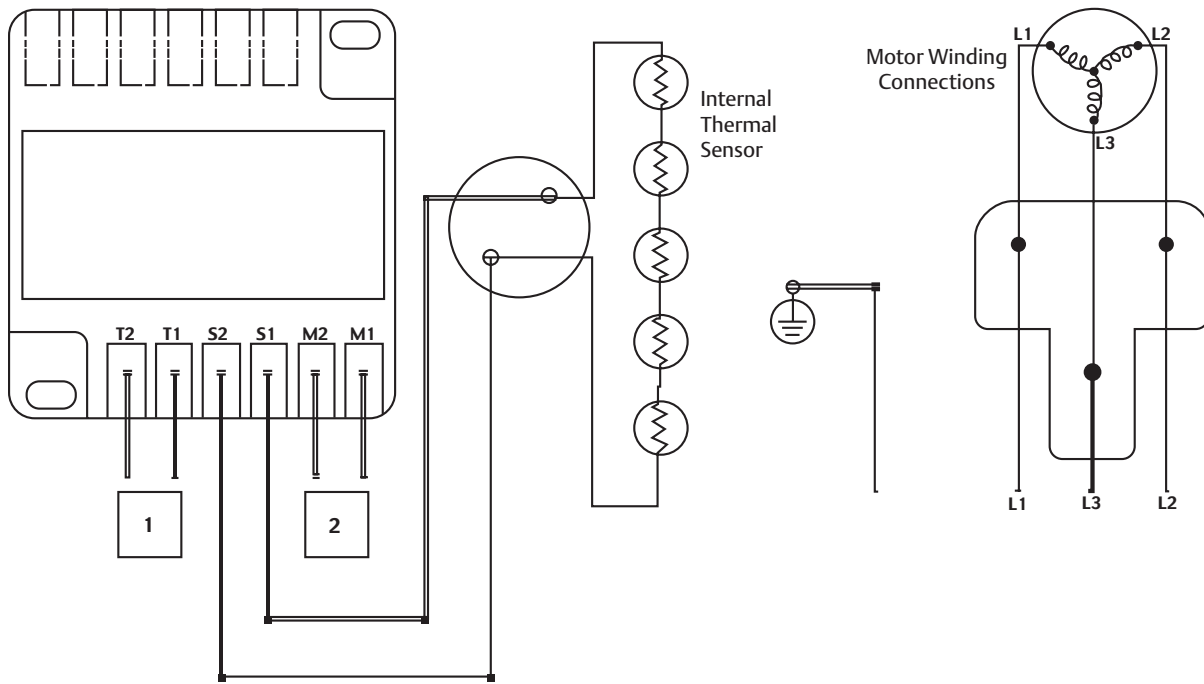

When checking solid state module, do not short across S1 and S2 sensor terminals.

Module has 30-minute time delay before reset in the event of protector trip.

 Thermal Sensors

 Protector module voltage

 To control circuit

ZB92-ZB11M Control Circuit

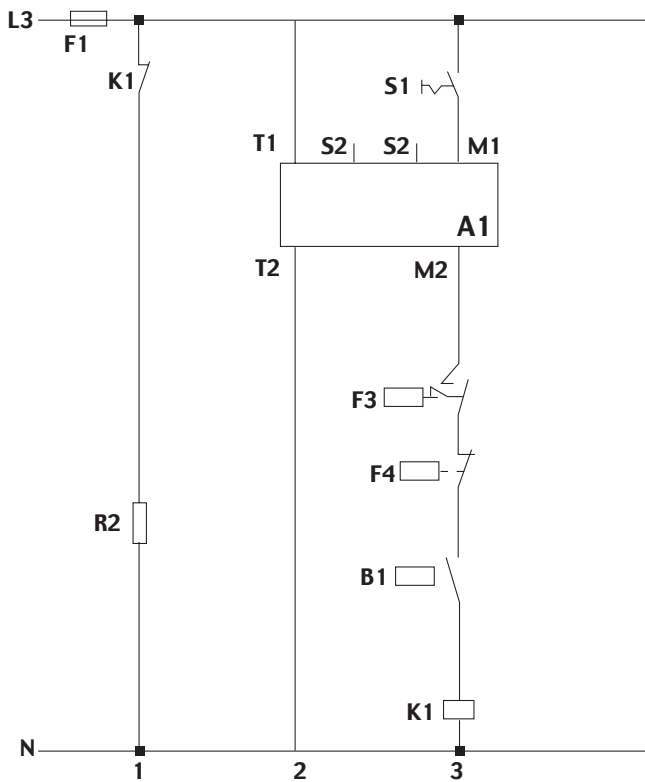

Electrical Schematics

A1: Motor Protection Module

B1: Temp Controller

F1: Fuse

F3: High Pressure Protector Switch

F4: Low Pressure Protector Switch

K1: Compressor Contactor

R2: Cranks case heater

S1: Manual Switch

ZB Series

Application Envelope

ZB15KQ~ZB88KQ, ZB92KC~ZB11MC
R22

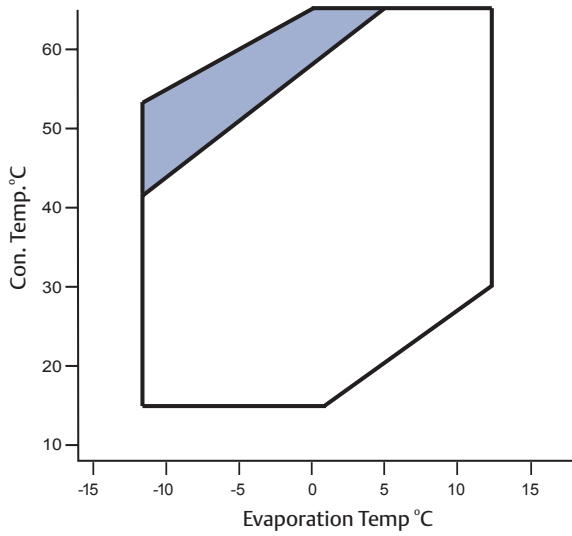

ZB15KQE~ZB76KQE, ZB92KCE~ZB11MCE
R404A/507

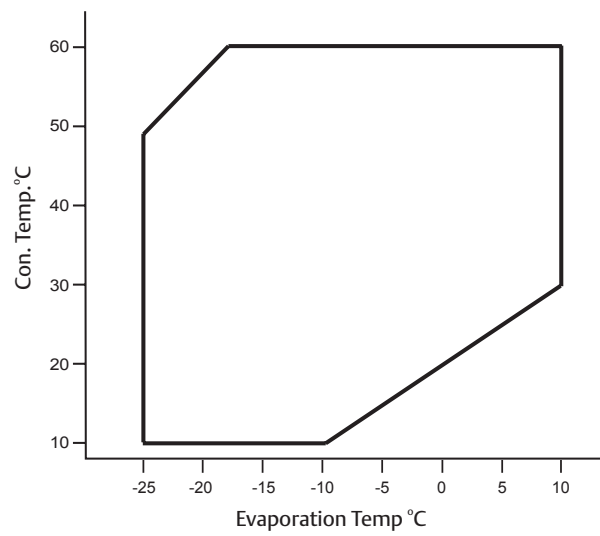

ZB15KQE~ZB76KQE, ZB92KCE~ZB11MCE
R134a

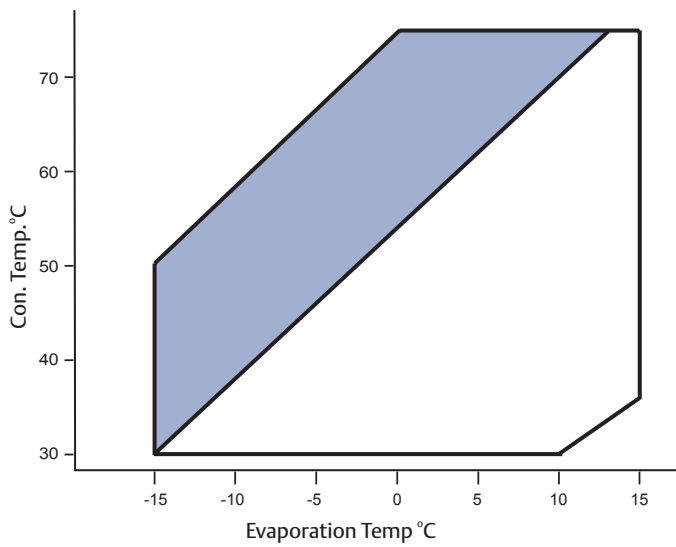

* Discharge Temp. Limit 126°C

* Maximum Superheat: 11K

* 20°C Suction temperature

ZB Series

Model Nomenclature

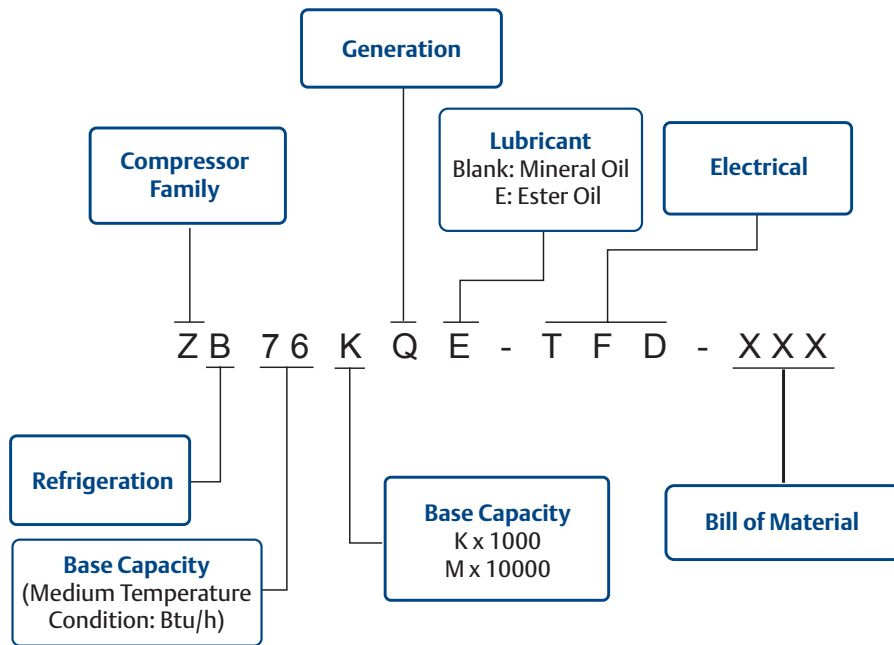

BOM Summary

Compressor Model	BOM Number	Suction & Discharge Tube Braze Connection	Suction & Discharge Tube Rotalock Connection	Oil Sight Glass	Schrader Valve
ZB15~ZB45	524	X			
ZB50~ZB88	524	X			
	523		X		
ZB92~ZB11M	551		X	X	X

Contact us at:

Asia Pacific Headquarters

Emerson Climate Technologies Ltd.
10/F, Pioneer Building
213, Wai Yip Street
Kwun Tong, Kowloon
Hong Kong S.A.R
P.R.China
Tel: (852) 2866 3108
Fax: (852) 2520 6227

Australia

Emerson Climate Technologies Australia Pty Ltd
Unit R7, 391 Park Road, Regents Park
NSW 2143
Australia
Tel: (61-2) 9795 2800
Fax: (61-2) 9738 1699

China - Beijing

c/o Emerson Climate Technologies (Suzhou) Co. Ltd
Beijing Representative Office
Room 310, Canway Building
66, Nan Lishi Road
Xicheng District
Beijing 100045
P.R.China
Tel: (86-10) 6805 7825
Fax: (86-10) 6805 6301

China - Guangzhou

c/o Emerson Climate Technologies (Suzhou) Co. Ltd
Guangzhou Representative Office
Room 1001, Dongshan Plaza,
69, XianLie Zhong Road,
Guangzhou 510095
P.R.China
Tel: (86-20) 8732 3008
Fax: (86-20) 8732 2568

China - Shanghai

c/o Emerson Climate Technologies (Suzhou) Co. Ltd
Shanghai Representative Office
16/F, Jiu Shi Tower
28, Zhong Shan Road (South)
Shanghai 200010
P.R.China
Tel: (86-21) 6333 0808
Fax: (86-21) 6333 0516

China - Shenyang

Emerson Climate Technologies (Shenyang) Co., Ltd
No.26, North 4 Middle Road
Tiexi District
Shenyang 110026
P.R. China
Tel: (86-24) 2587 8797
Fax:(86-24) 2564 2157

India - Registered & Head Office

Emerson Climate Technologies (India) Ltd.
1202/1, Ghole Road, Shivajinagar
Pune 411 004
India
Tel: (91-20) 2553 4988
Fax: (91-20) 2553 6350

India - Ahmedabad

Emerson Climate Technologies (India) Ltd.
17 / 18, Devang Society, Opp. Patel
Avenue, Nr. Gurudwara Gobind Dham
Gandhinagar Sarkhej Highway, Bodakdev
Ahmedabad - 380 054
Gujarat
India
Tel: (079) 26926648 / 26926649
Fax: (079) 2685 1758

India - Chennai

Emerson Climate Technologies (India) Ltd.
New No. 10, Postal Colony II Street, West Mambalam
Chennai - 600 033
Tamil Nadu
India
Tel: (044) 23718771, 23718772, 23718773
Fax: (044) 23718979

India - Kolkotta

Emerson Climate Technologies (India) Ltd.
35/7, Tollygunge, Circular Road, P.S. New Alipore,
Kolkotta - 700 053
West Bengal
India
Tel: (91-33) 24002779/ 24002781
Fax: (91-33) 24002784

India - Mumbai

Emerson Climate Technologies (India) Ltd.
Unit No. 4,5,6 & 7, Bhaveshwar Arcade, LBS Marg
Opp. Shreyas Cinema, Ghatkopar (West)
Mumbai - 400 086
Maharashtra
India
Tel: (91-22) 25006630 / 25006632 (O)
Fax: (91-22) 25006570

India - New Delhi

Emerson Climate Technologies (India) Ltd.
56, Rama Road Industrial Area
Near Mahindra Showroom,
New Delhi - 110 015
India
Tel: (91-11) 25111861, 5111862 / 3 / 4
Fax: (91-11) 25457748

India - Pune

Emerson Climate Technologies (India) Ltd.
Mahadeo Sadan
Near Pratidnya Mangal Karyalaya
Madhuban Colony
Opp. Alankar Police Chowky
Samartha Road, Karve Nagar
Pune - 411 052
Tel: (91-20) 25411401 / 402
Fax: (91-20) 25411411

India - Secunderabad

Emerson Climate Technologies (India) Ltd.
1141, Rashtrapathi Road
Nr. Sree Gujarati Seva Mandal,
Secunderabad - 500 003
Andhra Pradesh
India
Tel: (91-40) 27530834 / 35, 55260411
Fax: (91-40) 27530832

Japan

c/o Emerson Japan Ltd
Shin-yokohama Tosho Building No. 3
3-9-5, Shin-Yokohama
Kohoku-ku
Yokohama 222-0033
Japan
Tel: (81-45)475 6371
Fax: (81-45)475 3565

Korea

c/o Emerson Electric Korea Ltd
12F, Narae B/D
719-1, Yeoksam-dong
Gangnam-gu
Seoul
Korea 135-080
Tel: (82-2) 3483 1500
Fax: (82-2) 592 7883 / 592-7886

Malaysia

Emerson Electric (Malaysia) Sdn. Bhd.
Level M2, Block A, Menara PKNS-PJ
Jalan Yong Shook Lin
46050 Petaling Jaya, Selangor, Malaysia
Tel: (603) 7949 9339 (Direct)
(603) 7949 9222
Fax: (603) 7949 9333

Philippines

c/o Astec Power Ltd
33/F, Orient Square Building
Emerald Avenue, Ortigas Center
Pasig City
Philippines
Tel: (63-2) 687 6615 ext. 611
Fax:(63-2) 730 9546

Taiwan

c/o Emerson Electric (Taiwan) Co. Ltd
5th Floor, No.2 Jen Ai Road, Section 4
Taipei 10650
Taiwan
Tel: (886-2) 2325 9555
Fax: (886-2) 2702 9630/ 2784 0022

Thailand

Emerson Electric (Thailand) Ltd.
34th Floor, Nation Tower
46/133, Moo 10, Bangna-Trad Road
Bangna
Bangkok 10260
Thailand
Tel: (66-2) 716-4700
Fax: (66-2) 751-4240 / 751-4241

aprefrigeration@emersonclimate.com

EMERSON. CONSIDER IT SOLVED.™